

CARVERaudio.com

A Website Devoted to the Legacy of Bob Carver's Electronics

This, and all manuals found on CARVERaudio.com have been painstakingly scanned, compiled, cataloged and archived by our [dedicated forum members](#), for the benefit of all Carver audio fanatics. These manuals are NOT intended for re-sale. If you should find these manuals "For Sale" on any website, please report your findings to us, so we may have them removed.

CARVERaudio.com

CARVER

Model M-400, A, t

Magnetic Field Power Amplifier

Technical Service Manual

Carver Corporation

19210 33rd Avenue West

P.O. Box 1237

Lynnwood, WA 98046

THIS MANUAL IS INTENDED FOR USE BY QUALIFIED,
AUTHORIZED PERSONNEL.

HAZARDOUS VOLTAGES MAY BE ENCOUNTERED WHEN
SERVICING THE M-400. USE EXTREME CAUTION.

CONTENTS

1. Introduction	4
2. Specifications	6
3. Circuit Descriptions	9
4. Diagrams and Schematics	18
5. Test	39
6. Troubleshooting	45
7. Disassembly	49
8. Appendices	51
A. Design History	51
B. References	53
C. Parts	53
D. Service Bulletins	56
E. Questionnaire	57

Prepared 1981

Rev. 8/84

Carver Corp. Technical Services

1. INTRODUCTION

The Carver M-400 power amplifier is unique in electronic and mechanical design. It is designed to provide the listener with a source of voltage and current to drive high fidelity loudspeaker systems. It may be used as either a single-channel or dual-channel unit with very high efficiency of weight, size, heat dissipation and cost, with very low distortion and noise. Intended for use in the home high fidelity music system, it is capable of extremely high power output with excellent loudspeaker load-drive capability. The design has been optimized for home audio applications in which high power excursions are necessary to prevent distortion of dynamic transients, while bulk, weight, heat and price considerations have traditionally restricted use of such devices to a small number of consumers.

Efficiency has been dramatically improved by techniques which substitute electronic control for the large quantities of bulk copper, iron and aluminum required by conventional designs. This control factor in the power supply section is augmented by amplifier design which dissipates power as required on signal demand so that heat sinking and quiescent dissipation are held to a minimum. Distortion components typical of the more efficient traditional class AB designs are virtually eliminated by use of sliding idle current.

Comprehensive amplifier and loudspeaker protection is provided by conventional means, augmented by the controlled power-supply, which will shut down under unsafe conditions as determined by a separate sensing network. Analog computer techniques are used to monitor operational parameters and override the normal power supply control function in the event that operating conditions become unsafe for amplifier or loudspeakers.

The unit is built into a 6 3/4 inch cube enclosure made up of an anodized aluminum chassis, case, front-panel, and back cover. Four modular circuit

board assemblies are interconnected by 24K gold-plate connectors. Internal component density is high. Access via front-panel is adequate for many service operations, while removal of magnetic-field coil, case, back/cover, and supply filters allows access to all power supply parts. Service of amplifier PCBs may require their removal from the chassis.

2. TECHNICAL SPECIFICATIONS

The test specifications listed in this section are made in accordance with IHF-A-202, standard methods of measurement. The operator is referred to Section 5 for special procedures which are necessary for testing the M-400. Some changes in test specifications have occurred since production began, and will continue as improvements warrant.

2.1 Dimensions, Assembly

M-400 unit enclosure, made up of chassis, case, front-panel and back cover, measures:

Width 6 3/4 in.
Height 6 3/4 in.
Depth 6 15/16 in.

All chassis assemblies are black-anodized. Case, front panel, and back cover are available as champaign gold anodized or matte charcoal paint. There is no provision for rack mounting.

2.2 Output Power, Stereo 8 ohms

The M-400 is rated at 201 Watts per channel, continuous 20 Hz to 20K Hz, both channels driven into 8 ohms, at no more than 0.05% Total Harmonic Distortion.

Output power specification is valid if:

1. Rear-panel impedance selector switch is in the down, "stereo, 4 ohms and above" position (for units so equipped).
2. Line voltage does not drop below 110 Vrms.

2.3 Output Power, Below 8 ohms, Mono

The M-400 will deliver the following output power at clipping, at 2K Hz, under the respective load configurations:

Stereo 4 ohms - 255 Watts
Stereo 2 ohms - 265 Watts
Mono 8 ohms - 500 Watts
Mono 4 ohms - 400 Watts

Mono use into loads significantly below 4 ohms is not recommended.

2.4 Other Distortion Ratings

The M-400 will produce no more than 0.05% Intermodulation Distortion at all output power levels, as measured by the SMPTE method (60 Hz: 7K Hz, 4:1).

Transient Intermodulation Distortion (TIM) is unmeasurable, and the M-400 is not limited by slew-induced distortion at rated power, 20 Hz to 20K Hz.

The M-400 slew rate is a maximum of 40 V per microsecond.

2.5 Dynamic Headroom

As per IHF standard, the M-400 dynamic headroom rating is 2 dB.

2.6 Damping Factor

Damping factor is 150 at 20 Hz.

2.7 Frequency Response

At 1 Watt output, frequency response (excluding input and output filters) is 1 Hz to 250K Hz, +0 -3 dB. With input and output filters, 1 Watt frequency response is 7 Hz to 100K Hz, +0 -3 dB.

2.8 Signal-to-Noise Ratio

A minimum 100 dB S/N Ratio is maintained, referenced to rated output, IHF-A weighted.

2.9 Separation

Channel separation in the stereo mode is 60 dB at 1K Hz, minimum.

2.10 Input Impedance and Sensitivity

The input impedance of each channel is 15K ohms. An input signal level of no more than 1.5 Vrms is required to drive the M-400 to full rated power output.

2.11 Display

The channel tracking of the LED display is rated at ± 1 LED indicator with equal output from both channels.

0 dB full-power reference is at 200 Hz, 40 Vrms output.

Display ballistics are peak-responding, with a nominal 1 mS attack, 50 mS decay across the full 6 LEDs.

2.12 Supplemental Specifications

A. The shipping weight of the M-400 is 12 lb.

B. The line current demand of the M-400 is as follows for the respective power output into 8 ohms, stereo:

Idle	-	0.5 A
20 Watts	-	4.0 A
100 Watts	-	9.0 A
200 Watts	-	14.0 A

These specs are valid for 110 V units only.

C. 220 Volt Conversion: The M-400 power supply may be converted from 110 Volt to 220 Volt operation (or from 220 to 110) ONLY at the Factory Service Facility.

The M-400 may be operated at either 50 Hz or 60 Hz, so the use of a step-down transformer from a 220 V Mains supply is possible. The transformer must be able to supply the necessary current (see "B", above).

This is a BLANK page

or

a schematic Diagram that was attached after the last page

The Triac firing angle in the M-400 is preset at idle to its maximum value, then continuously altered to respond to the load demand of the amplifiers.

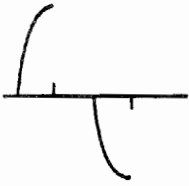

Triac voltage @ 90° firing angle

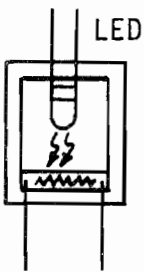

LDR (VTL5C3) Optocoupler

The phase-control RC network which determines the firing angle contains fixed elements which limit the firing angle to just slightly more than 90 degrees (95 typical). This maximum limit corresponds to the saturation level of the transformer core and to the voltage rating of the secondary filter capacitors.

The DC voltages in the secondary circuits are monitored by a feedback regulation system made up of the regulator transistor (Q6) and sense lines taken from the +50, +75, and -75 DC rails. Refer to Figure 1.

An LDR (Light-Dependent Resistor) forms half of a divider (OC-1 and R57) across the AC line. The value of the LDR resistance determines:

1. The Triac firing angle,
2. Secondary DC voltages.

An LED in the optocoupler package shines on the LDR, and varies its resistance. LED brightness is proportional to Triac firing and supply operation as follows:

1. LED bright - Supply OFF
2. LED dim - Supply ON

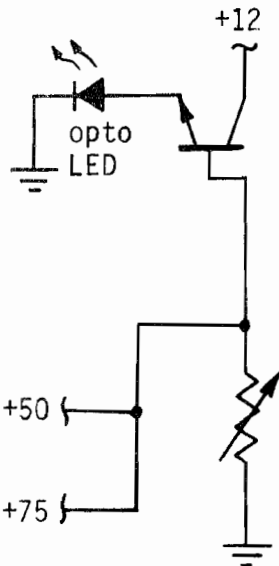

The LED brightness is adjusted by the state of the regulator transistor (Q6). At idle (no signal through, or load on, the amplifiers), the regulator idle reference is trimmed and preset by RPI so that the secondary voltage does not exceed safe limits.

As the amplifiers are driven into a load and the secondary DC voltages decrease, the regulator transistor is driven near cutoff, dims the LED and increases the Triac firing angle. This serves to maintain high efficiency at idle, yet provides adequate current to drive speaker loads at extremely high power.

The regulator transistor is referenced directly to the +75 and +50 VDC supplies via a divider, and to the -75 VDC supply by means of an IC op-amp inverting attenuator. Asymmetrical pull on the 75 VDC supply (possible in some new recordings) will not cause the regulator to mistrack the power demand of the amplifiers.

The reference of the regulator is also user-resettable by SW-1, which acts to reduce the triac firing angle, and reduce the DC supply voltages, when the M-400 is used to drive extremely low load impedances or is bridged for single-channel use.

The secondary circuit of the power supply consists of three "tiered" levels of rectification and capacitive filtering, providing the amplifiers with voltages required.

The 25 VDC supply, the innermost tier, consists of the appropriate transformer secondary winding, two paralleled bridge rectifiers and a set of four 2200 uf filters. This supply operates the two output transistors per channel which see full wave audio and directly drive the speaker load.

The 50 VDC supply, the intermediate tier, is made up of a separate bridge and an additional pair of 2200 uf filters "stacked" on those of the 25 V supply. It operates two output transistors per channel which switch on to prevent the inner pair from clipping, as required by the signal.

The 75 VDC supply is independently filtered and includes a high-current bridge rectifier. It powers the highest tier of output transistors to provide full rated output.

All three main supply levels are unregulated, and will thus fluctuate with current demand. This fluctuation is reduced by the action of the feedback regulator, so that the main supply levels are held up as demand increases from the amplifiers.

A zener diode-regulated ± 12 VDC supply is used to power all op-amps, LEDs, and small-signal transistors, including the regulator transistor, the display drive and the shutdown-protection system.

3.2 Amplifiers

Each channel of the M-400 amplifier is independent with respect to signal, while both are powered by a common supply system. The two channels operate 180 degrees out of phase when both input signals are in phase.

The input signal drives the Left channel front-end op-amp non-inverting input, while it drives the Right channel op-amp inverting input. When connected to loudspeakers according to speaker terminal color coding (with Left channel speaker "reversed"), relative phasing between the speakers is maintained correctly.

Operating of the two channels 180 degrees out of phase offers the following performance advantages:

1. At low frequencies, where stereo music signals are commonly within a few degrees of being in phase at all times, greater full power output may be obtained by pulling symmetrically on the positive and negative sides of the power supply.
2. If a single-channel input is paralleled to both channels, a single loudspeaker may be connected across the two "hot" outputs of both channels. Super-high-power Mono operation is possible, without an external passive phase inverter (bridging adapter).
3. Certain unique protection advantages may be realized. See Section 3.3.

In both channels, the front-end op-amp functions as a differential input stage, reducing distortion with moderate amounts of negative feedback.

The operational amplifiers are high-speed BI-FET devices which have a high immunity to slew-induced distortions, low noise, and high stability.

Negative feedback is phase compensated to stabilize the amplifier into a wide variety of load impedances and reduce distortion, while not interfering with the high speed and definition of the amplifier.

Forward bias is controlled by bias transistor Q8 and generated by Q18.

Trim control RP1 adjusts the forward bias necessary to provide the appropriate "sliding" idle current, which virtually eliminates crossover notch distortion while maintaining high efficiency.

Bias transistor Q8 is mounted to the output transistor heatsink to provide thermal tracking.

Op-amp output is tied to level-shifter transistors Q20 and Q21, which provide voltage gain to the predriver transistors Q17 and Q19.

Output-Driver transistors Q7 and Q9 provide drive to the output transistors, which are configured for emitter-follower operation. A set of two output transistors per channel switch the output toward the highest supply voltage rail available, as determined by the Commutator in response to the demand of the input signal. Additional output transistors comprise the Commutator.

The purpose of the Commutator is to anticipate the potential saturation of the output stage by an input signal voltage which could overdrive the output. The "inner" pair of output transistors acts as a 20 watt linear amplifier, but is fully capable of swinging the entire positive and negative 75 Volt supply. The Commutator substitutes higher voltage rails as necessary, slightly in advance of the saturation of the inner pair of outputs, on a cycle-by-cycle basis.

Referring to the block diagrams, the output of a single sine-wave cycle is shown with respect to the three tiers of the power supply and the operation of the output stage of the amplifiers.

When the 25V supply is adequate to provide the drive signal with required output current gain, the output transistors tied to the 50V and 75V rails are at cutoff. As input signal drives the first tier of output transistors near saturation, an additional pair will begin to operate in their linear regions, preventing saturation. A system of multiple diode-drops is used to operate the 50V Commutator, so that the 50V supply will be switched on, tracking the audio, preventing saturation and delivering the required additional current gain.

Since the 50V supply operates the main driver transistors, some additional gain is required to operate the 75V Commutator, which also has its own independent supply filters for greater current reserve. The emitter-follower drive for the 75V Commutator is configured with frequency specialized R/C lead networks to insure that the 75V Commutator will respond in advance of actual demand.

A filter-pole is inserted between the amplifier output stage and the loudspeaker terminals, to attenuate ultrasonic frequency response.

3.3 Protection

Protection functions are shared by the amplifiers and the power supply. The amplifiers are protected from short-term excess current through the output stage by electronic current-limiters. A primary line fuse will open if excess current is drawn. A thermal switch mounted on the chassis near the output transistors will also open the primary circuit of the power supply if heatsink temperature exceeds output transistor safe-operating-area.

The amplifier current-limiter circuits operate by monitoring the voltage across the output transistor emitter resistors (R3 and R4). This voltage is proportional to the current through the output transistors. Limiter transistors (Q15 and Q16) will turn on to shunt drive current instantaneously when excessive output current is detected.

The triac-control system which adjusts primary supply power is also used to shut off the amplifier if unsafe conditions are detected by a shutdown/protection system.

Three "sense lines" monitor the operation of the amplifiers into the speaker load. Each is set up to trip a logic-comparator circuit which will turn on the LED portion of the opto-coupler and "open" the primary circuit of the power supply via the triac. These three sense lines are as follows:

(1) DC/Low Frequency Differential. The output of the amplifiers is summed by R13 and R14. Since the two channels operate at a 180 degree phase relationship at all times, only L-minus-R output will cause a voltage to develop at this summing junction. An RC time constant made up of R13, R14 and C4 makes it possible for only high-level, low-frequency differential input audio signals to operate this sense line.

The net effect is that any significant DC on a pre-amplifier's outputs will cause the M-400 to shut down, as will large amounts of out-of-phase low-frequency input signal, possible only if a phono stylus/tonerarm is mishandled at a high preamplifier Volume setting.

(2) Output Power Integrator. The M-400's overall efficiency is possible because audio/music signals in home playback systems typically have a moderate to large range of dynamics. Power on the order of 200 watts/channel

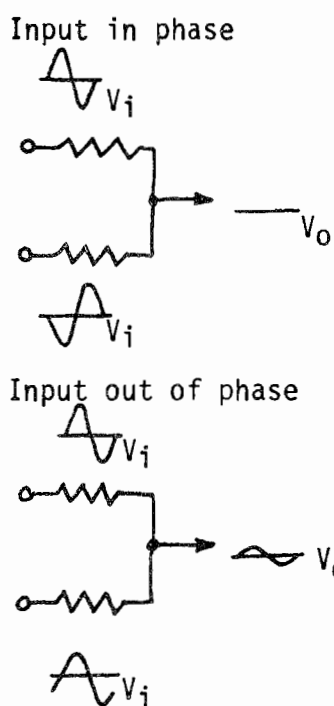

is required for undistorted output of sounds twice as loud as the loudest undistorted sound from a 20 watt/channel amplifier, but when peak dynamic requirements are 200 watt, the average output will rarely be higher than 80 watt in a home system. The design of the M-400 is thus uniquely suited to home high-fidelity systems.

The function of the Integrator is to monitor the integral of output power peak-to-average ratio over time to determine:

- 1) The effective dynamic range of the input signal relative to the average output power, and
- 2) To thereby approximate the thermal-stress history of the loudspeaker being driven.

Neither the amplifier nor the loudspeakers will ever see an excessively high power level over time (especially at high frequencies) with typical audio in a home system. The greater the dynamic range, the lower the integral of peak-to-average power over time, and the less susceptible the amplifier and speakers are to stress damage.

The integrator circuit half-wave rectifies the amplifier output (D15, D16) in order to compensate for the two amplifiers operating out of phase. Output voltage charges a capacitor which will trip the Shutdown Comparator. High-frequency weighting is added to make the system more sensitive to high output/time at frequencies which are (1) less common in music and (2) more damaging to loudspeakers. Output clipping is virtually the only source of such high-frequency high-output/time in home systems.

(3) Over-Current Trip. The current limiters in each amplifier are monitored by a circuit (Q1, etc.) which will also trip the Shutdown Comparator if high current causes the limiters to remain on more than a few hundred milliseconds. This condition will normally only occur with a direct short (0.5 ohms or less) across the amplifier outputs.

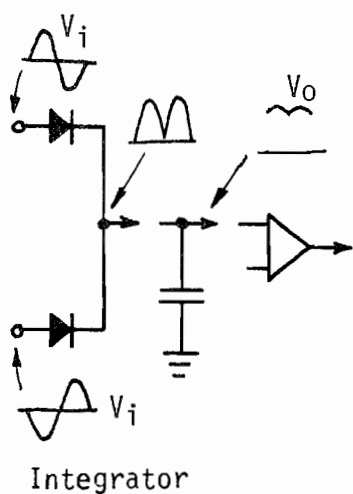
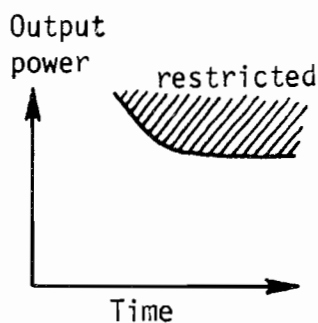

The Shutdown Comparator is an op-amp which will switch high if any of the shutdown trip-lines indicate unsafe operation. The comparator output switches the shutdown drive transistors, which turn on the LED in the optocoupler to turn off the supply via the triac.

Once the comparator has been tripped, it will remain in the off state until the supply has completely discharged. If the DC or overcurrent fault persists, only a dim blinking of display will occur. When the fault is removed, normal operation will resume. The Integrator will hold the supply in shutdown until the integrator cap has discharged. If input signal is present, the M-400 may make a pulsing sound every time the supply "tries" to come on.

3.4 Display

The six-LED display is driven by the output of the amplifiers. Output voltage is scaled by a log amp which provides 40 dB of dynamics and low-frequency weighting. Fast attack, slow decay ballistics are provided by RC time constant C13/R65 and C10/R32. DC output of this drive circuit operates an array of comparators which switch the individual LEDs.

4. DIAGRAMS AND SCHEMATICS

Included in this section are:

Functional Block-Diagrams

Schematic Diagrams

Schematic Overlay Block-Diagrams

Parts Locator Diagrams

Foil Pattern Diagrams

of the following circuit boards:

Power Supply

Original

New (see Appendix A)

Left Amplifier - Upper

Right Amplifier - Lower

Display

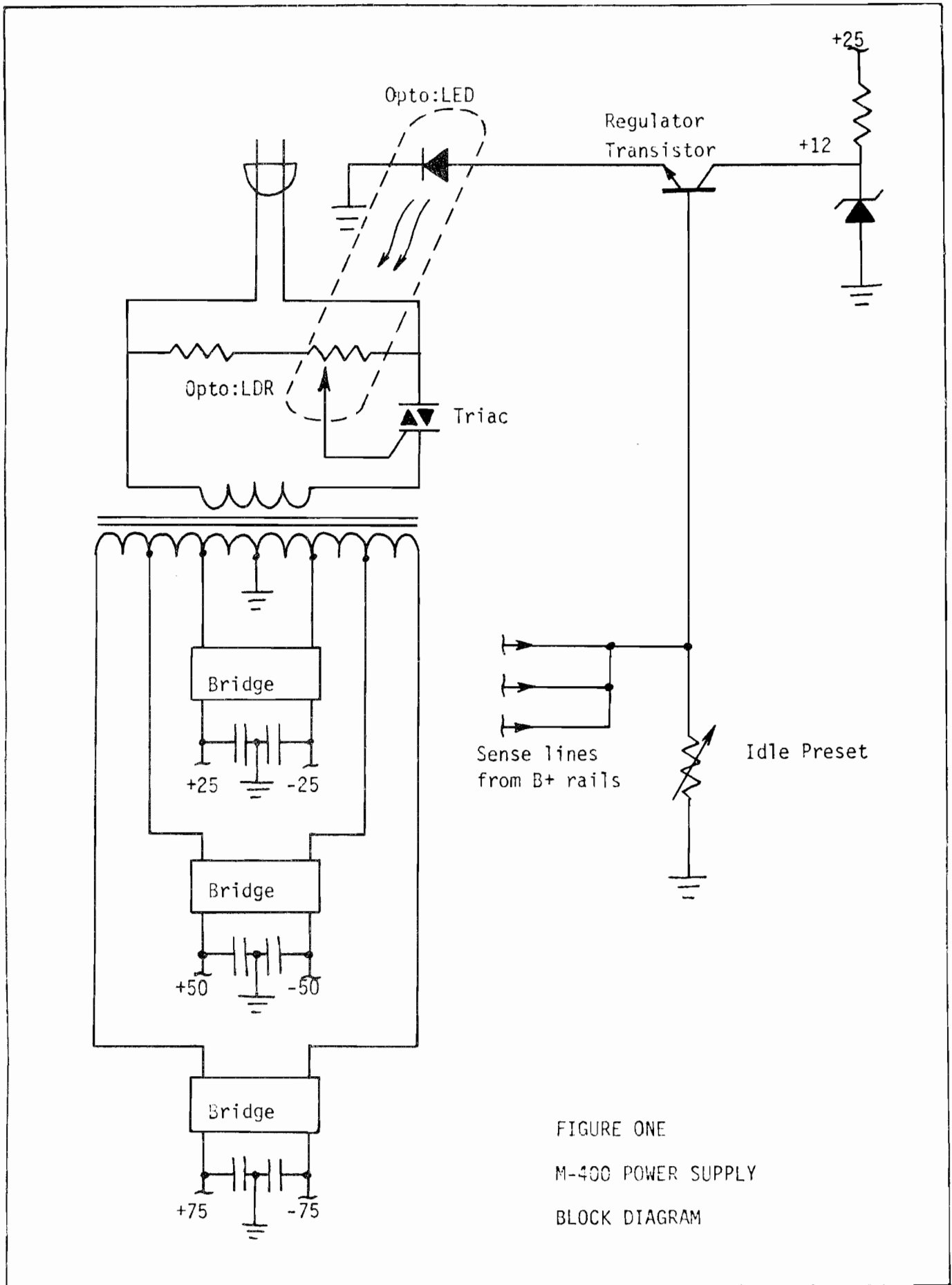

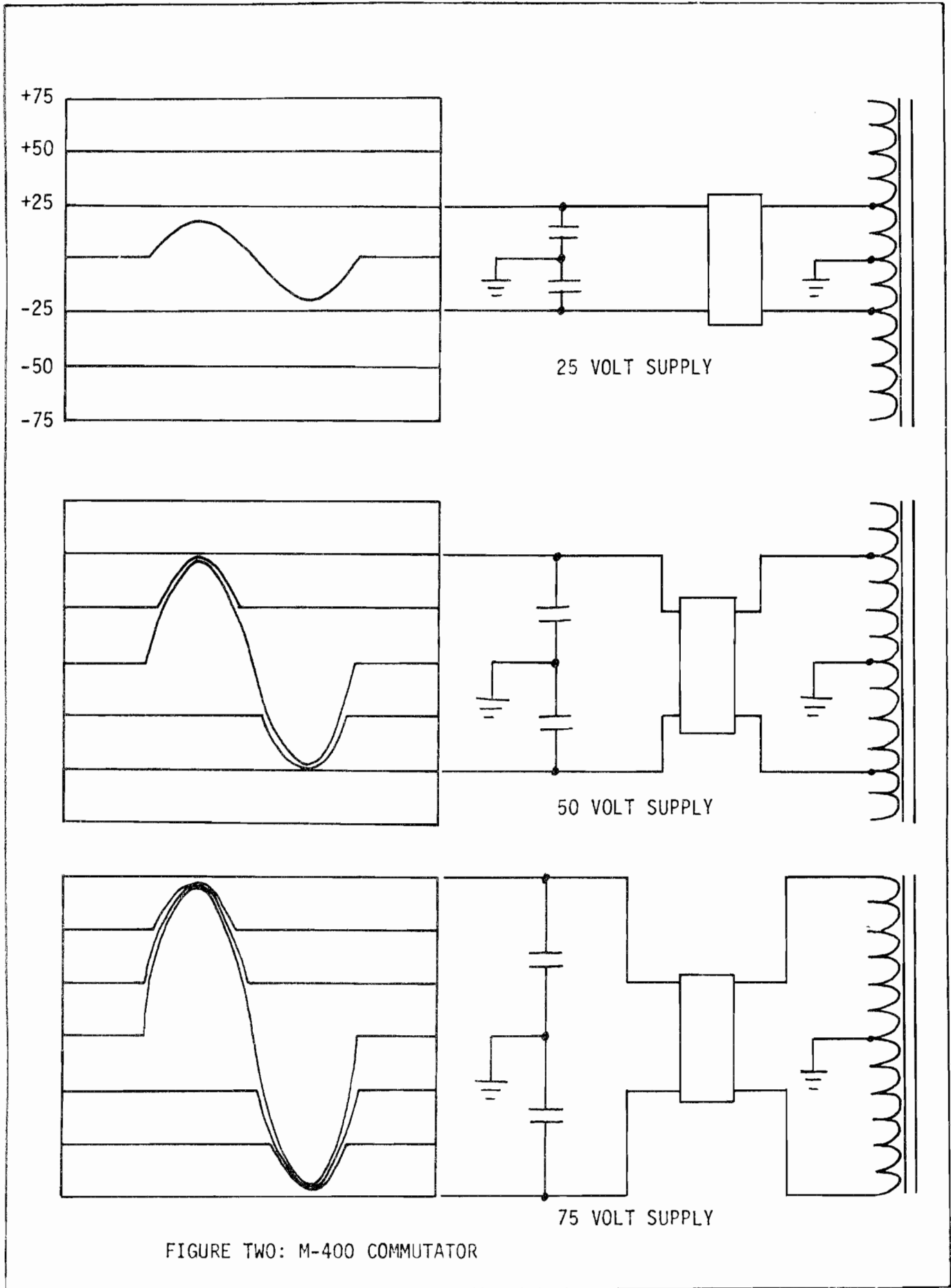

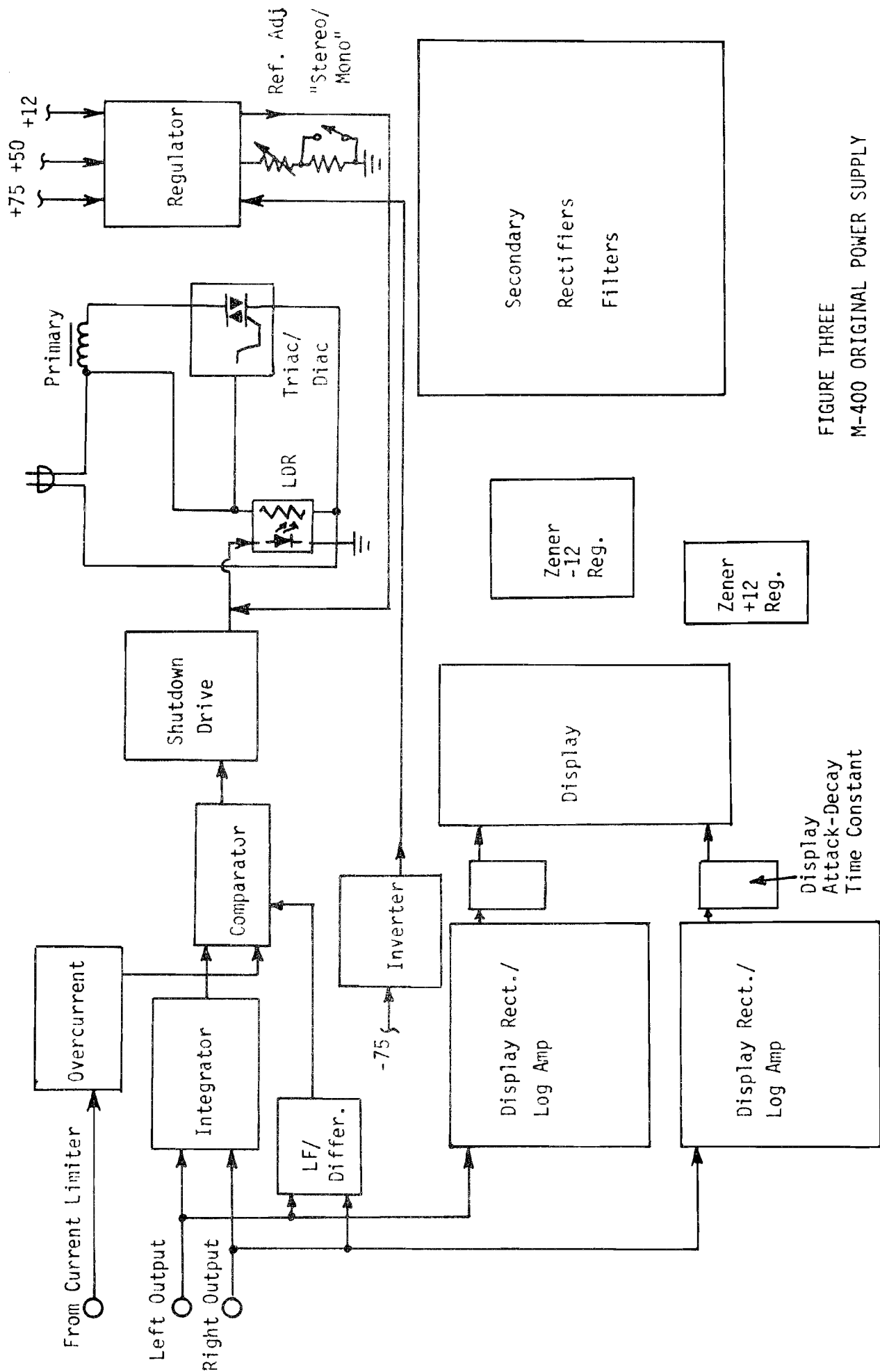
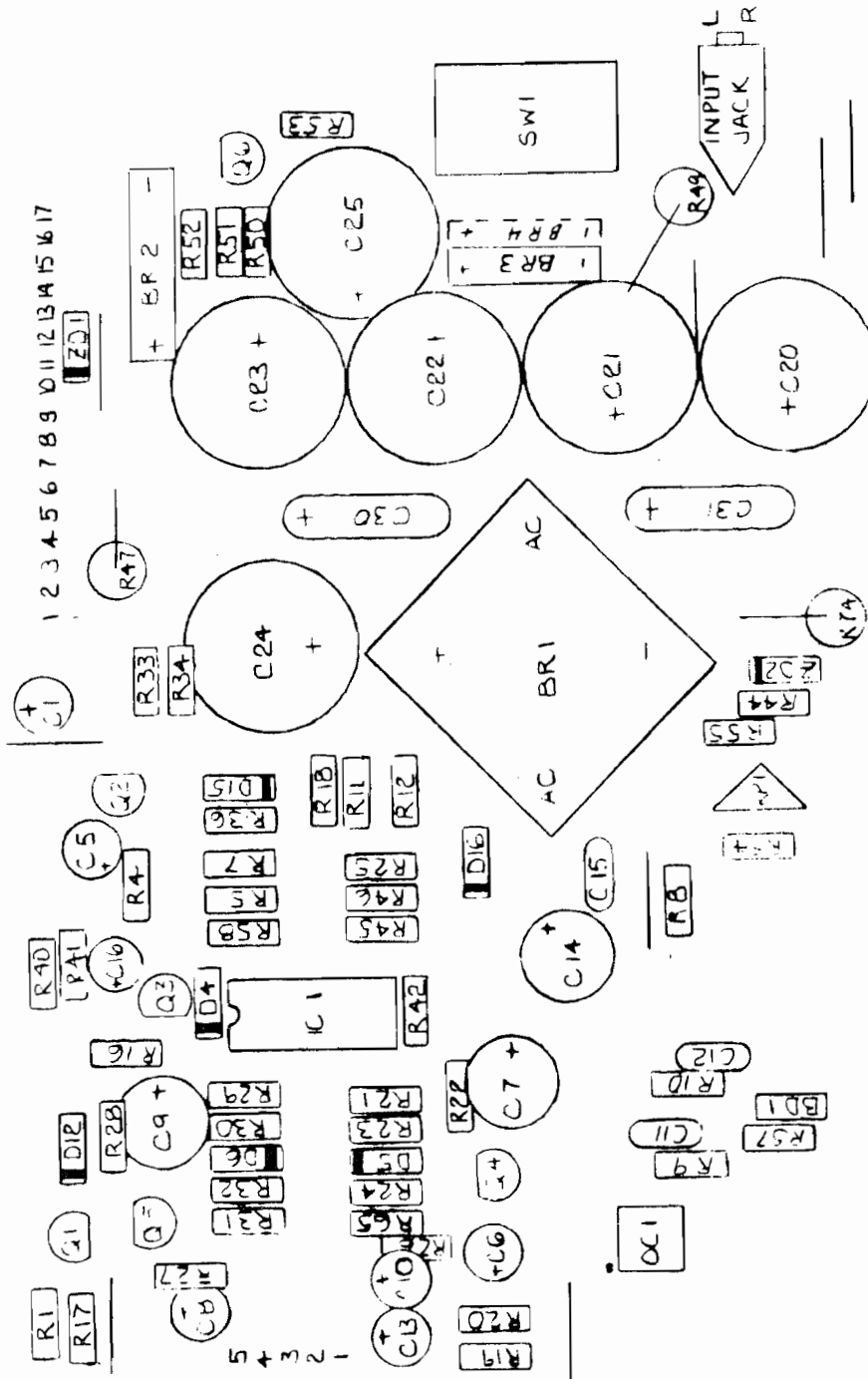

FIGURE THREE
M-400 ORIGINAL POWER SUPPLY
Schematic Overlay

CARVER MODEL M-400 MAGNETIC FIELD POWER AMPLIFIER
ORIGINAL POWER SUPPLY

Parts Locator



Note; Original power supply has rear-panel "impedance" switch.

CARVER CORPORATION
POWER SUPPLY 20022-1 REV 1

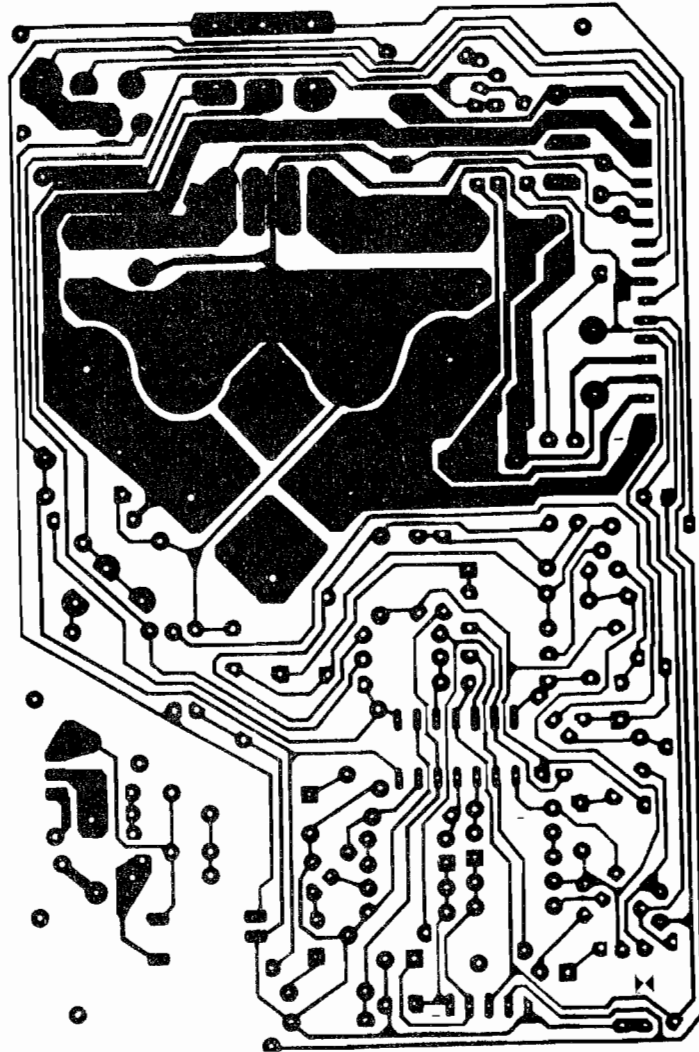

CARVER MODEL M-400 MAGNETIC FIELD POWER AMPLIFIER
ORIGINAL POWER SUPPLY Foil Pattern Diagram

FIGURE FOUR
M-400 NEW POWER SUPPLY Schematic Overlay

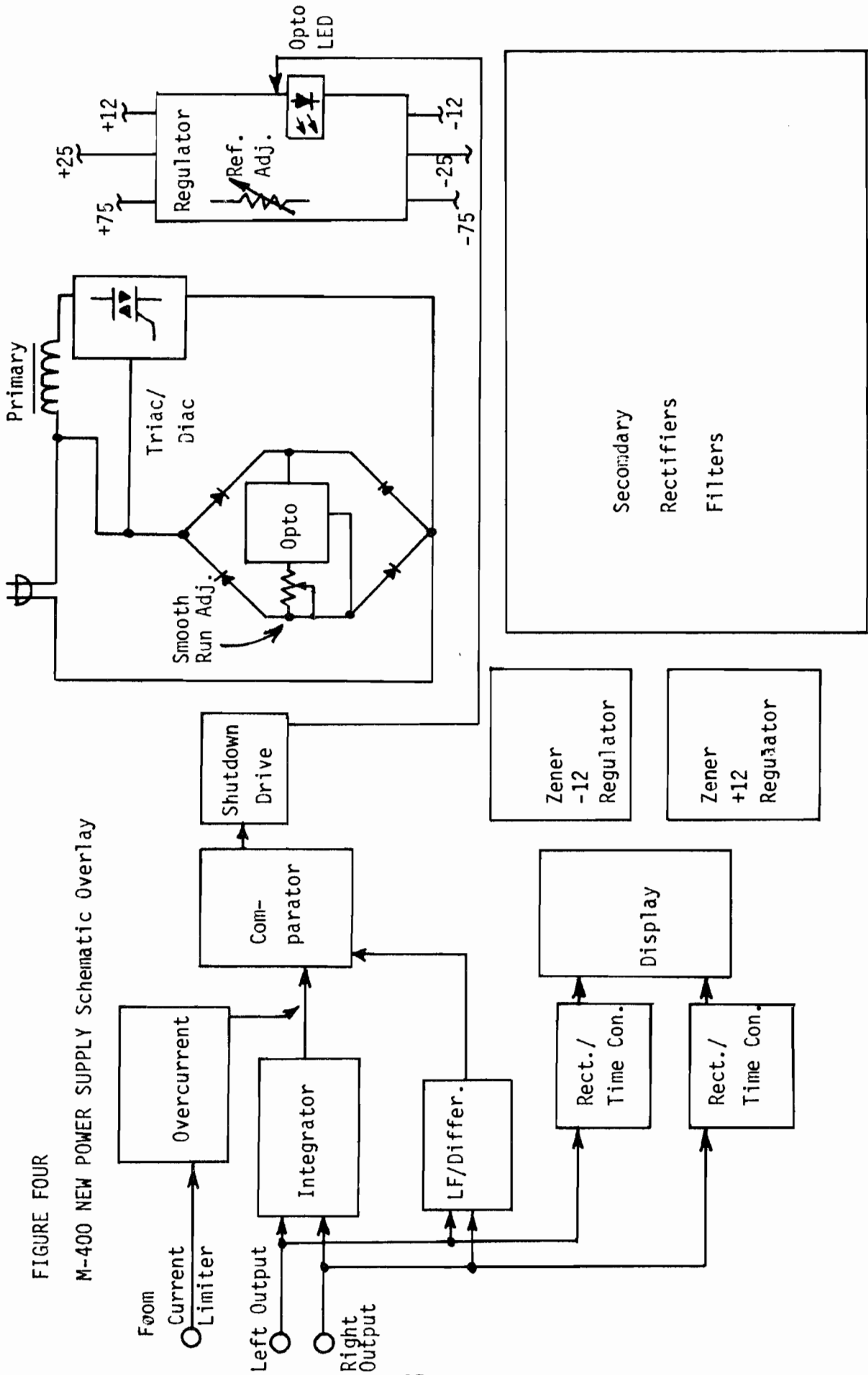

CARVER MODEL M-400 MAGNETIC FIELD POWER AMPLIFIER

NEW POWER SUPPLY Schematic

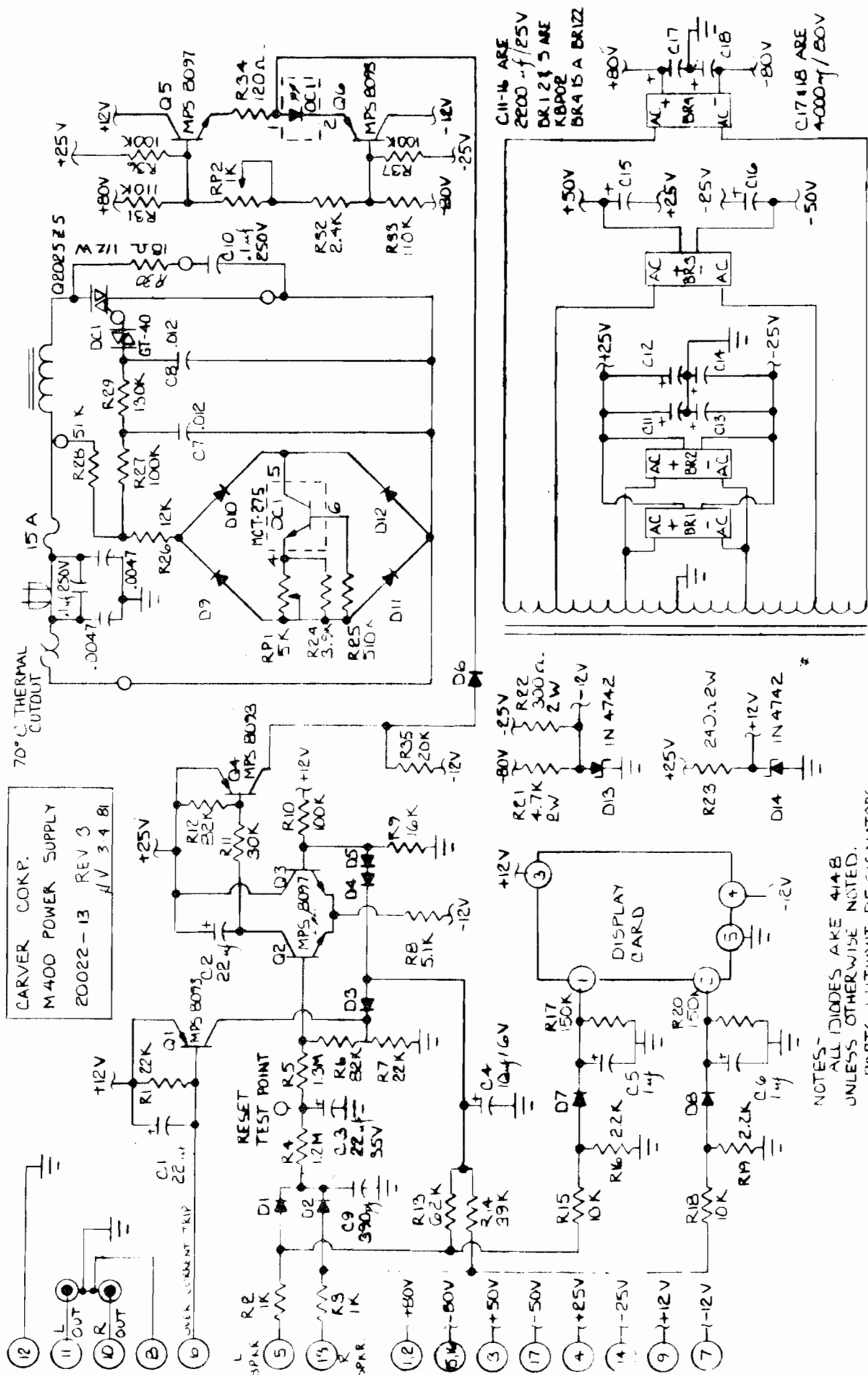

CARVER COKP.
M400 POWER SUPPLY
20022-13 REV 3
1/4 V 3 4 B1

NOTES:
ALL DIODES ARE 414B
UNLESS OTHERWISE NOTED.
PARTS WITHOUT DESIGNATORS
ARE NOT MOUNTED ON BOARD.

Note: New power supply DOES NOT have rear-panel "impedance" switch.

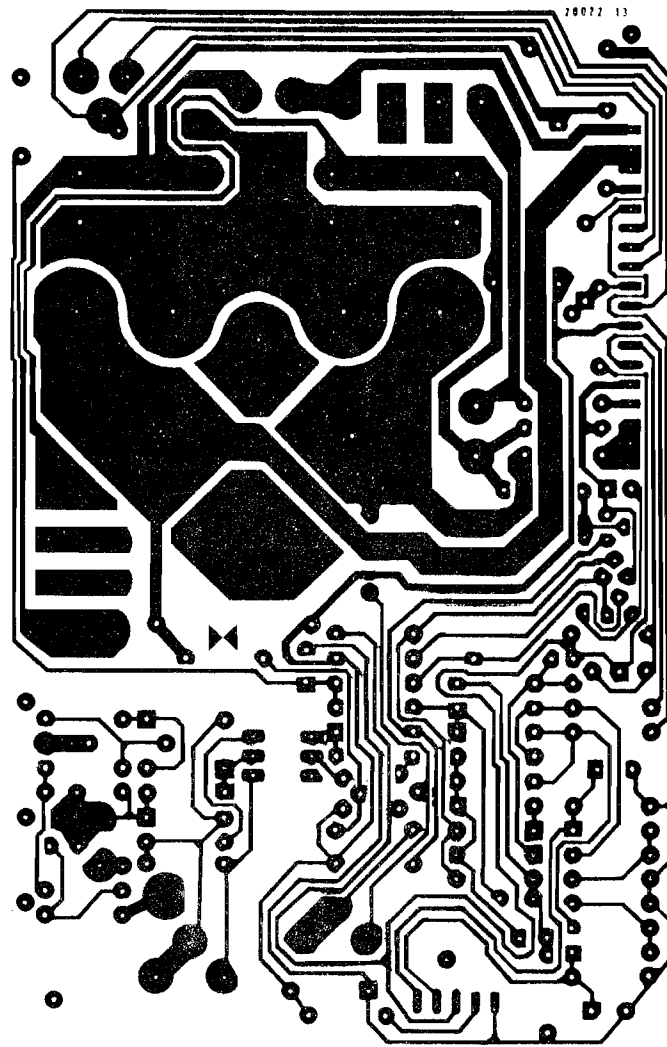

CARVER MODEL M-400 MAGNETIC FIELD POWER AMPLIFIER
NEW POWER SUPPLY Foil Pattern Diagram

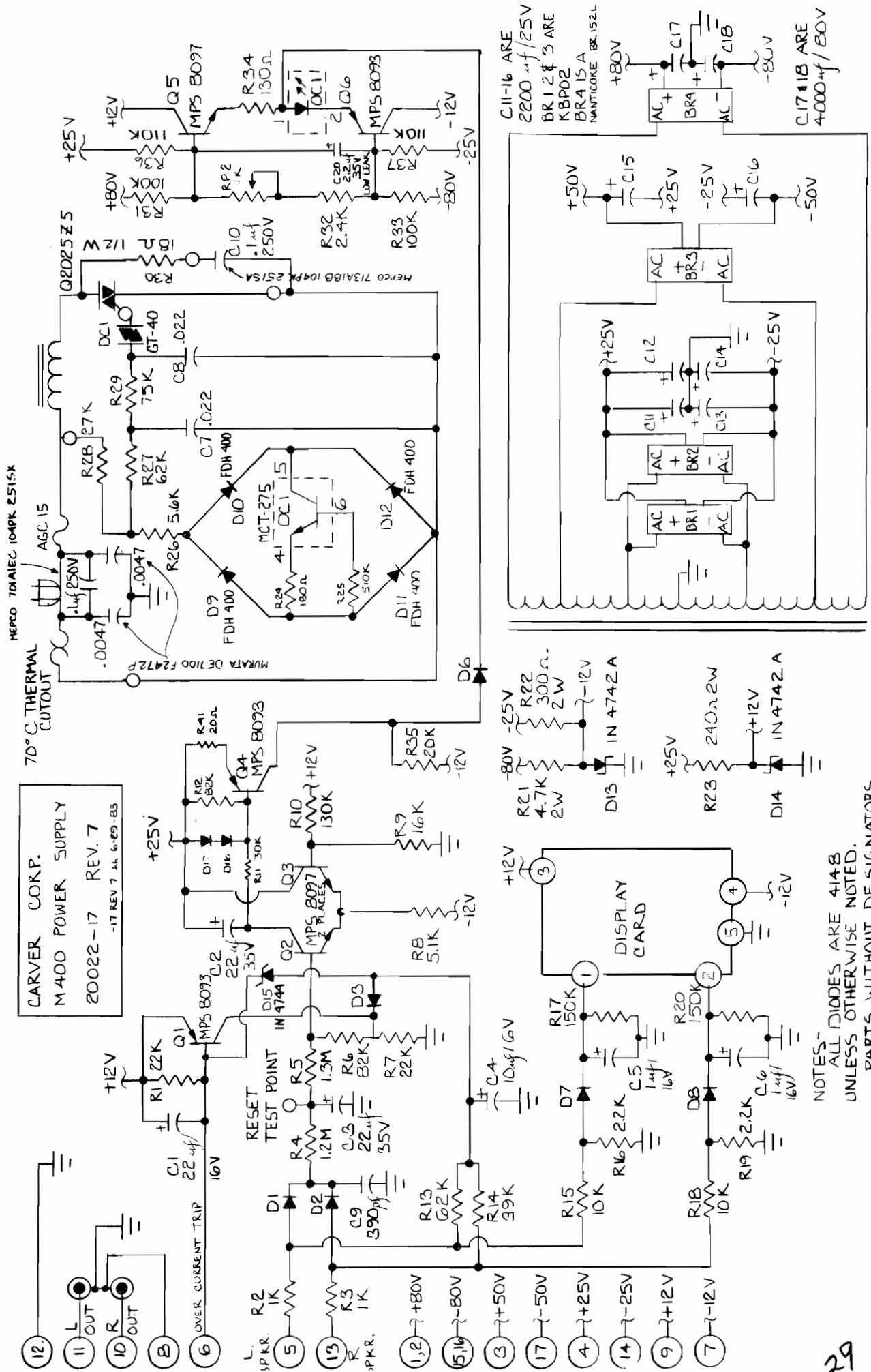

CARVER CORPORATION
 M-400 POWER SUPPLY
 20022-17

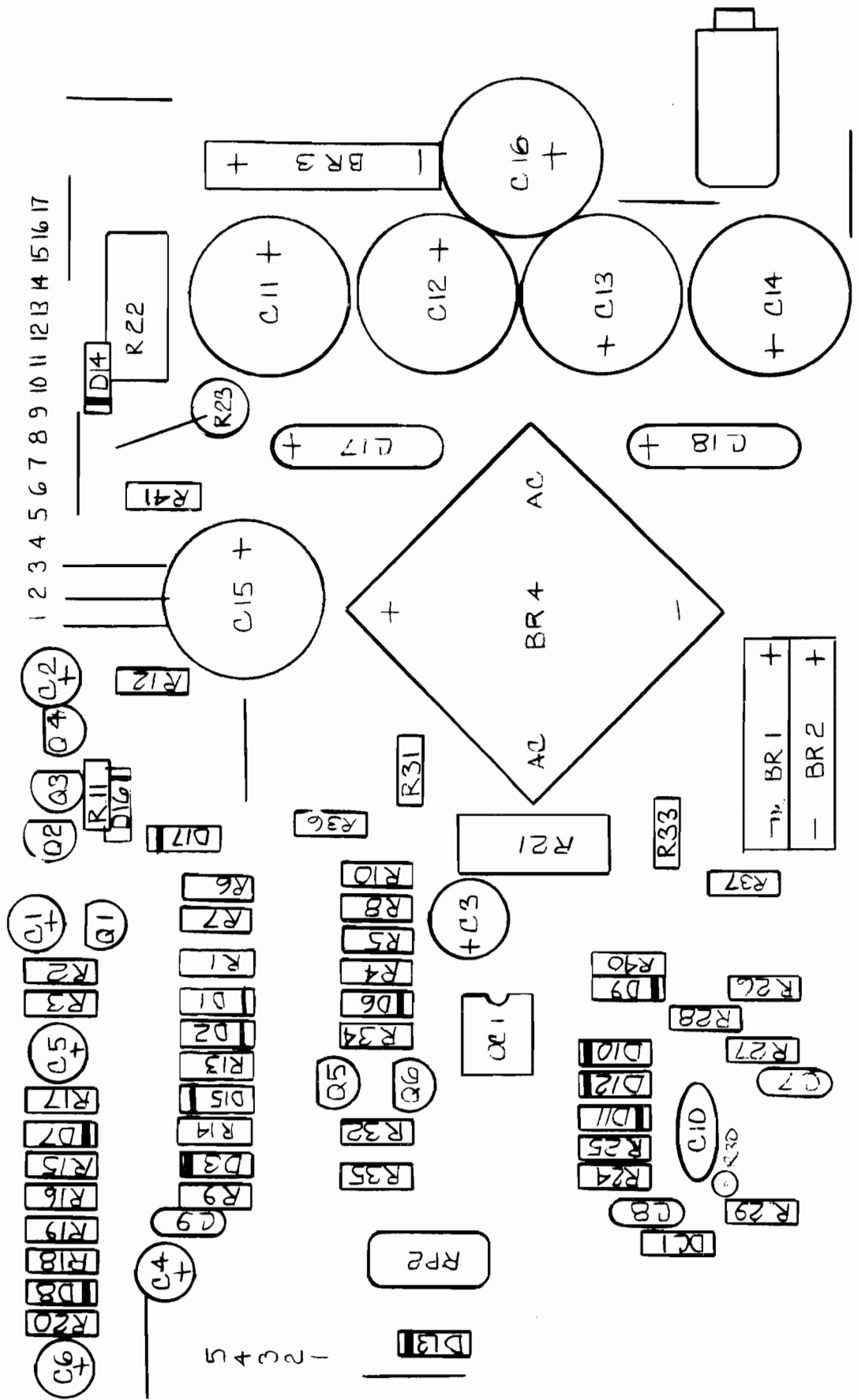

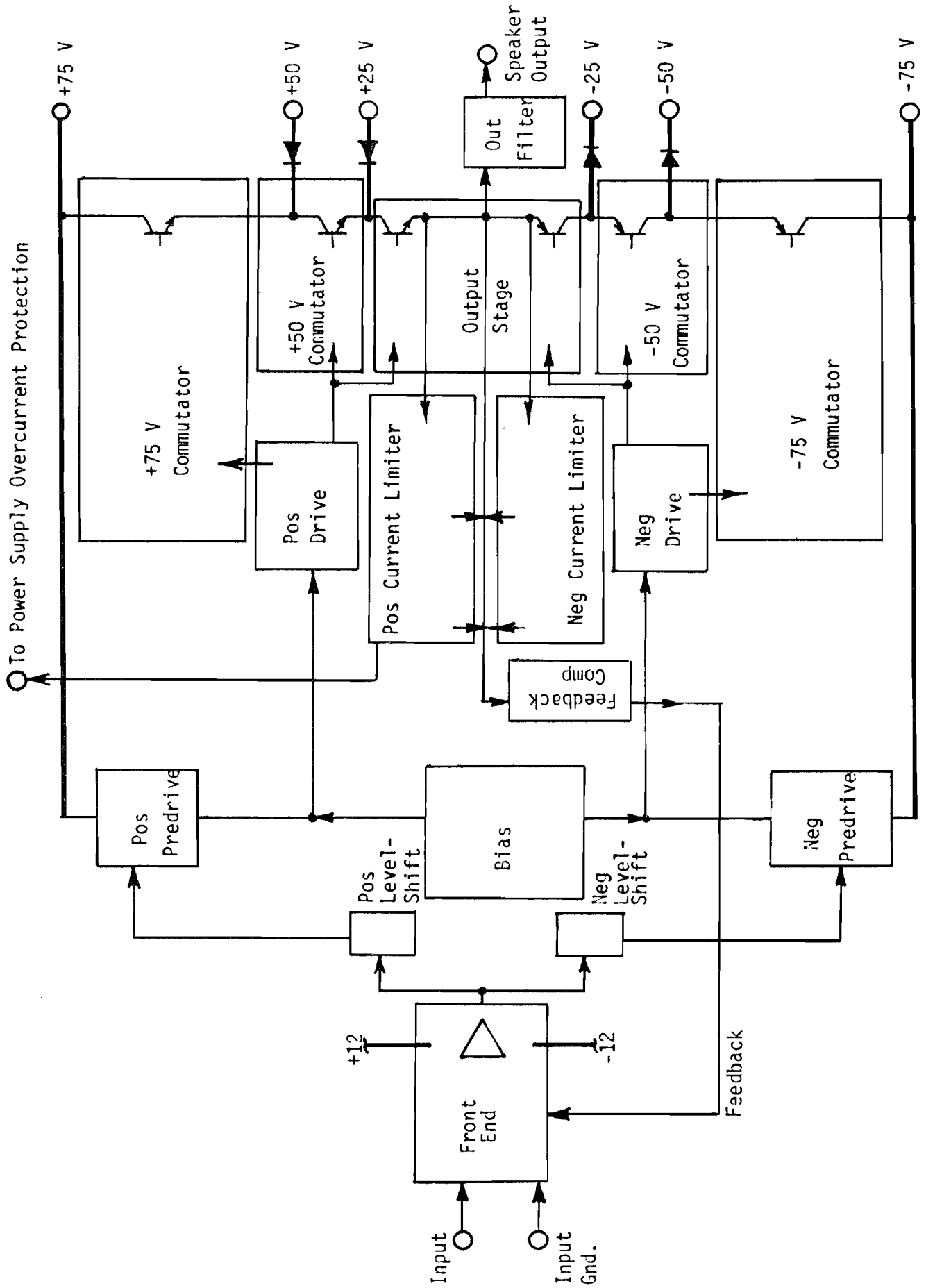
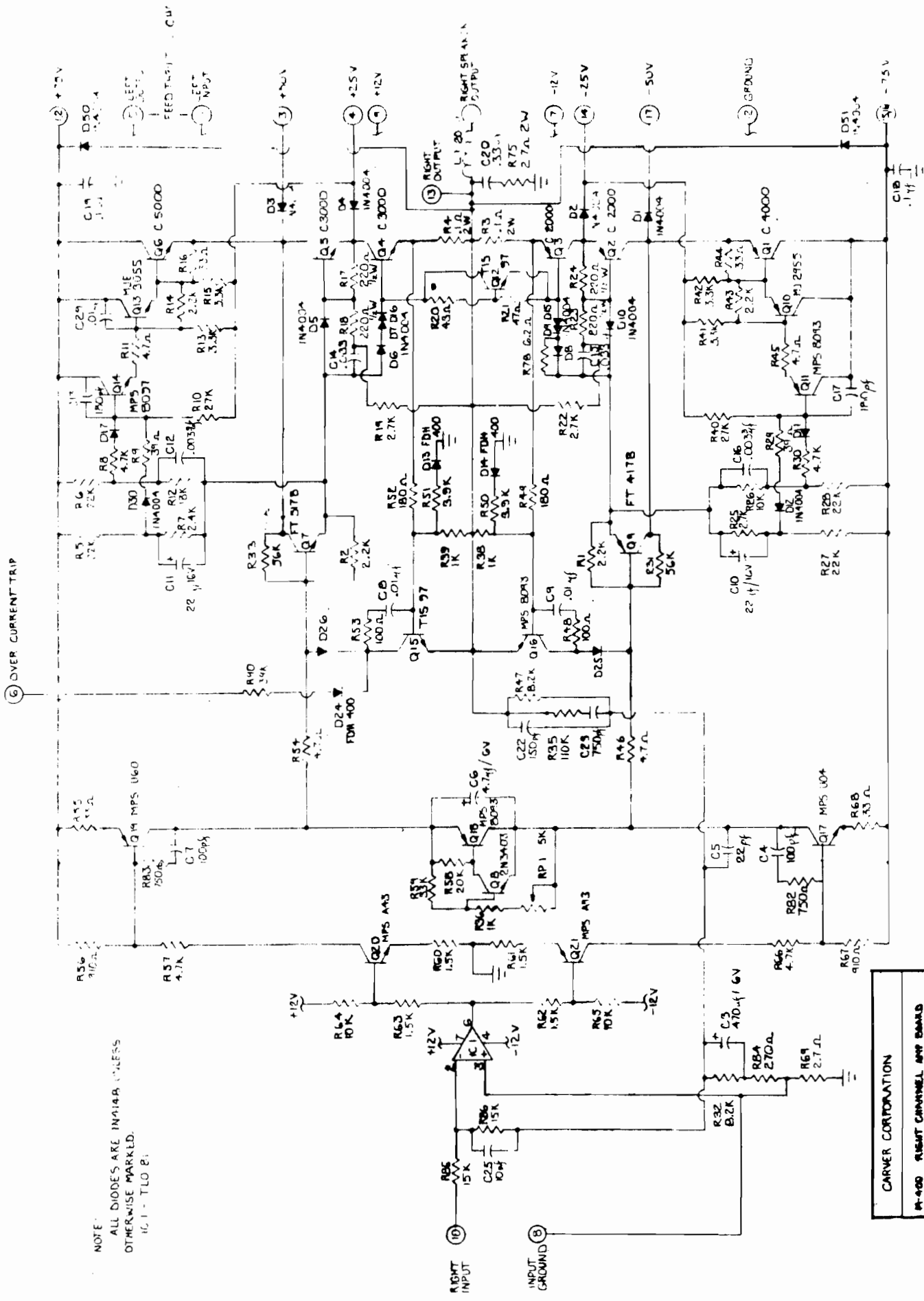

FIGURE FOUR: M-400 AMPLIFIER Schematic Overlay



CARVER CORPORATION	
M-400	RIGHT CHANNEL AMP BOARD
REV. 02/82	Part No. 20921-7
DATE	REV. 1
BY	H.V. 3-48

CARVER MODEL M-400 MAGNETIC FIELD POWER AMPLIFIER
RIGHT CHANNEL AMPLIFIER
Schematic

CARVER MODEL M-400 MAGNETIC FIELD POWER AMPLIFIER

RIGHT CHANNEL AMPLIFIER

parts locator

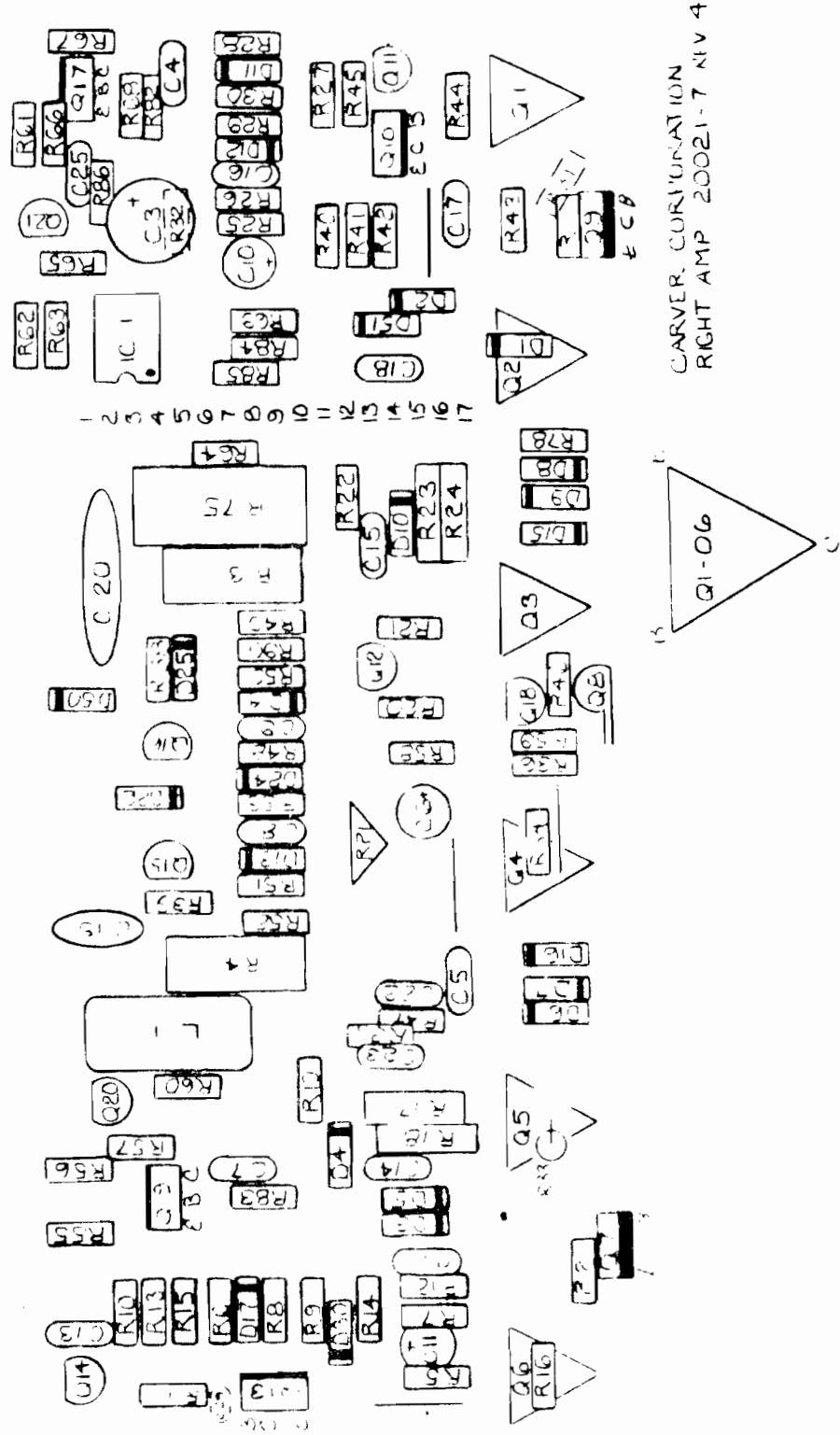

CARVER CORPORATION
RIGHT AMP 20021-7 REV 4

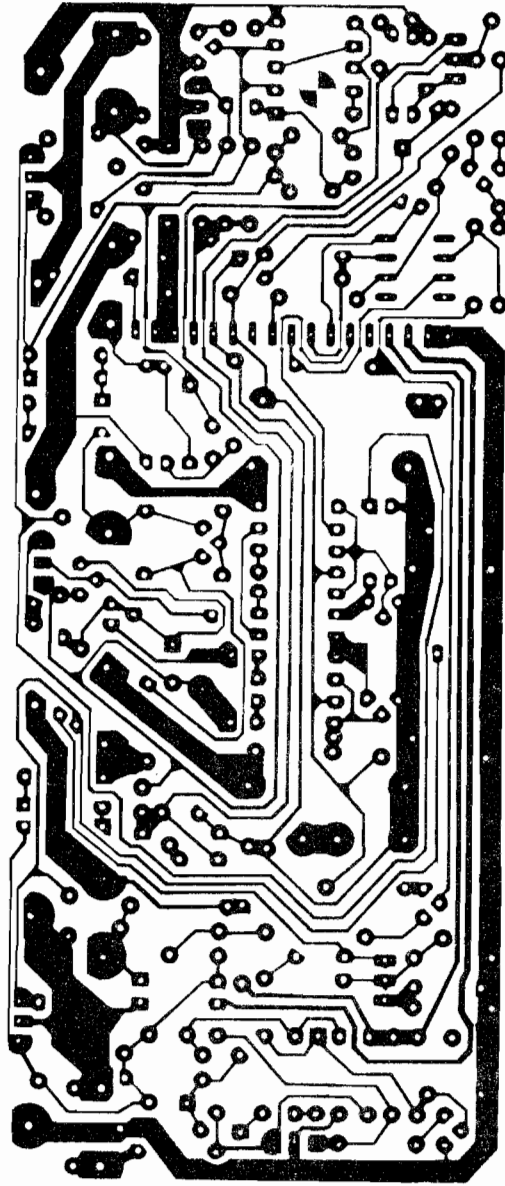

CARVER MODEL M-400 MAGNETIC FIELD POWER AMPLIFIER

RIGHT CHANNEL AMPLIFIER

Foil Pattern Diagram

CARVER MODEL M-400 MAGNETIC FIELD POWER AMPLIFIER LEFT CHANNEL AMPLIFIER Schematic

(E) OVER CURRENT TRIP

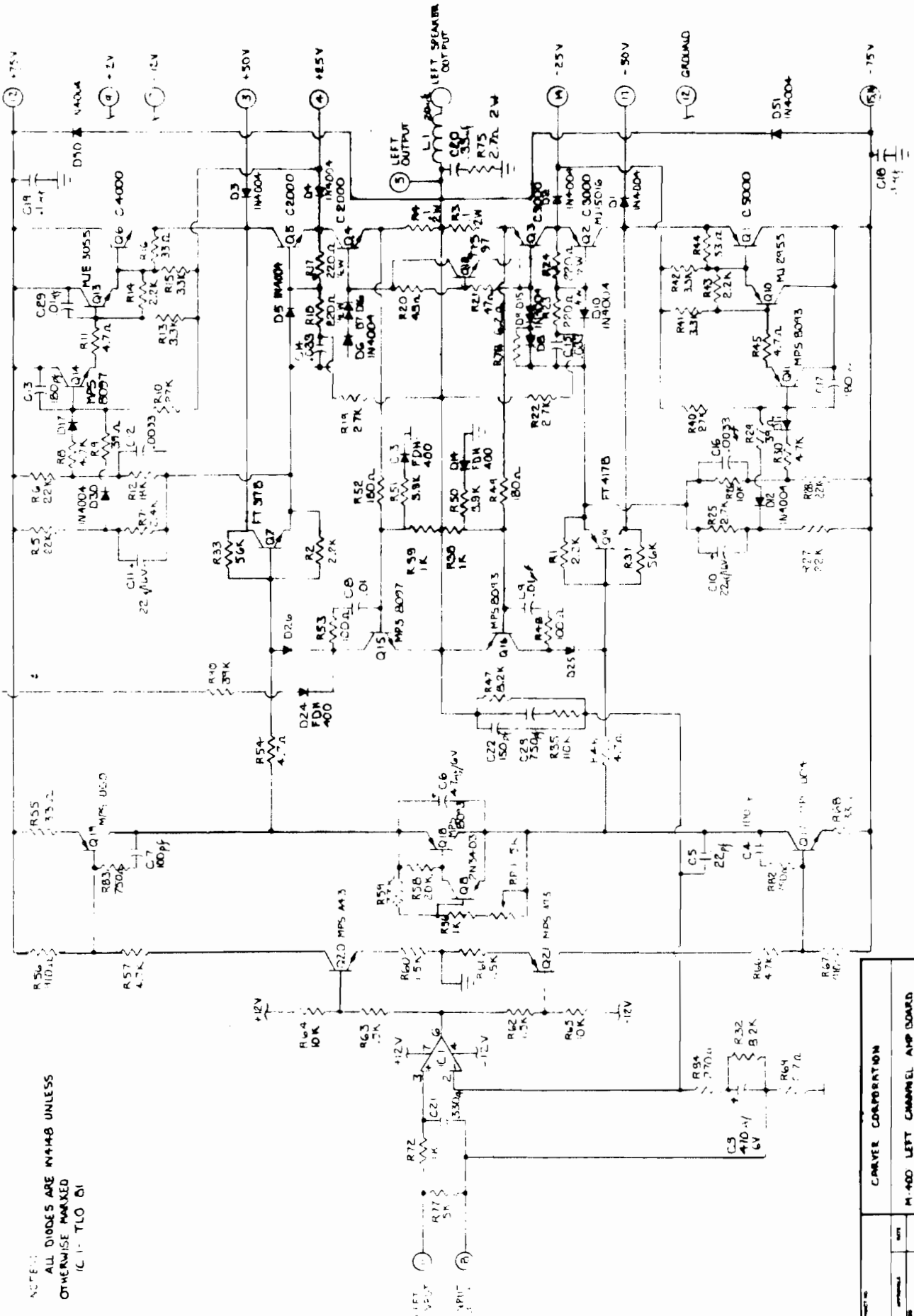

NOTES:
 ALL DIODES ARE 1N4148 UNLESS OTHERWISE MARKED
 (C 1 - TLO DI)

CARVER CORPORATION	
M-400 LEFT CHANNEL AMP BOARD	
REV	REV 10
DATE	2002.3-G
BY	1.02.1

CARVER MODEL M-400 MAGNETIC FIELD POWER AMPLIFIER

LEFT CHANNEL AMPLIFIER

CARVER CORPORATION
20023-6 REV 4

Parts Locator

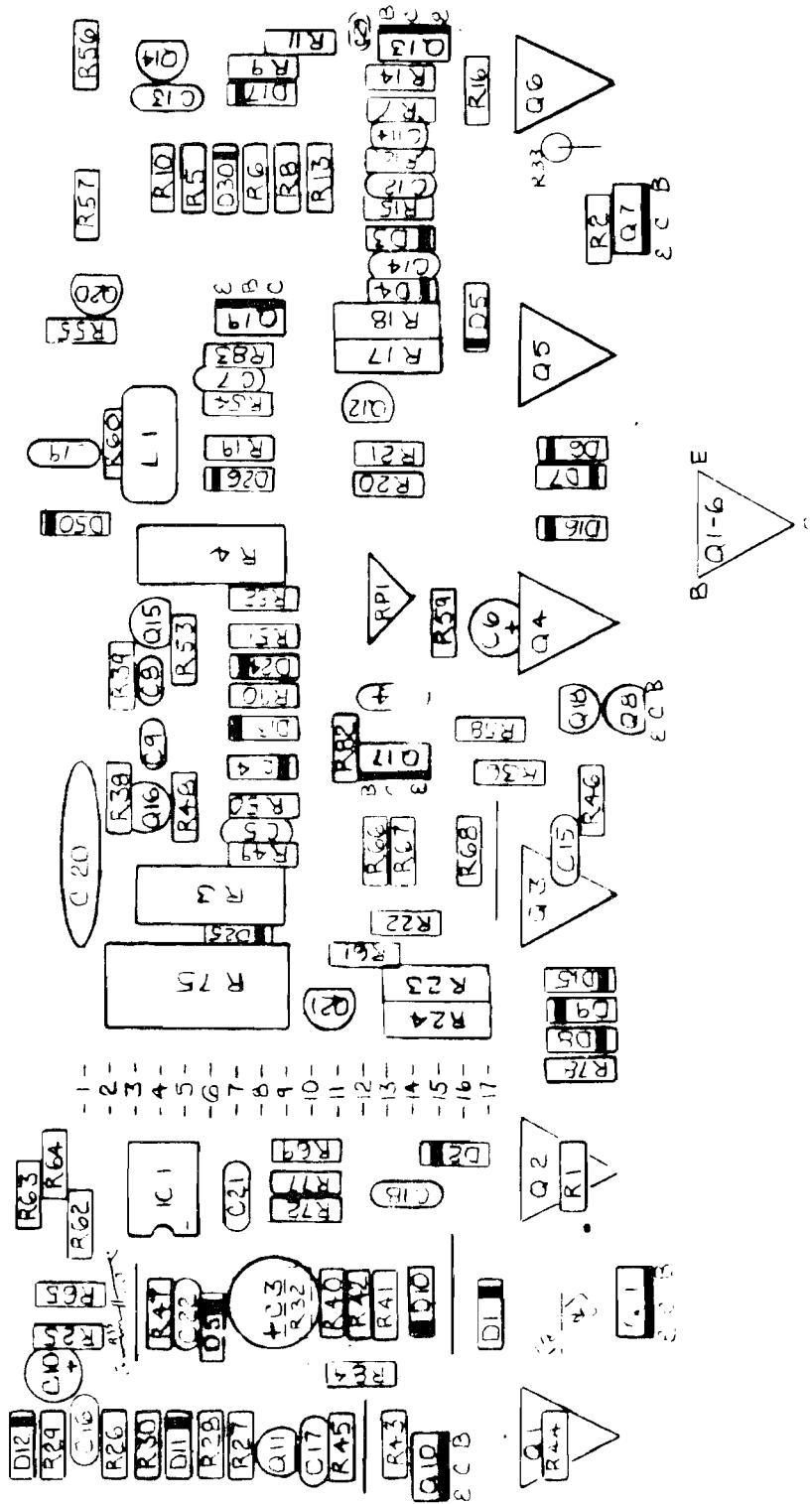

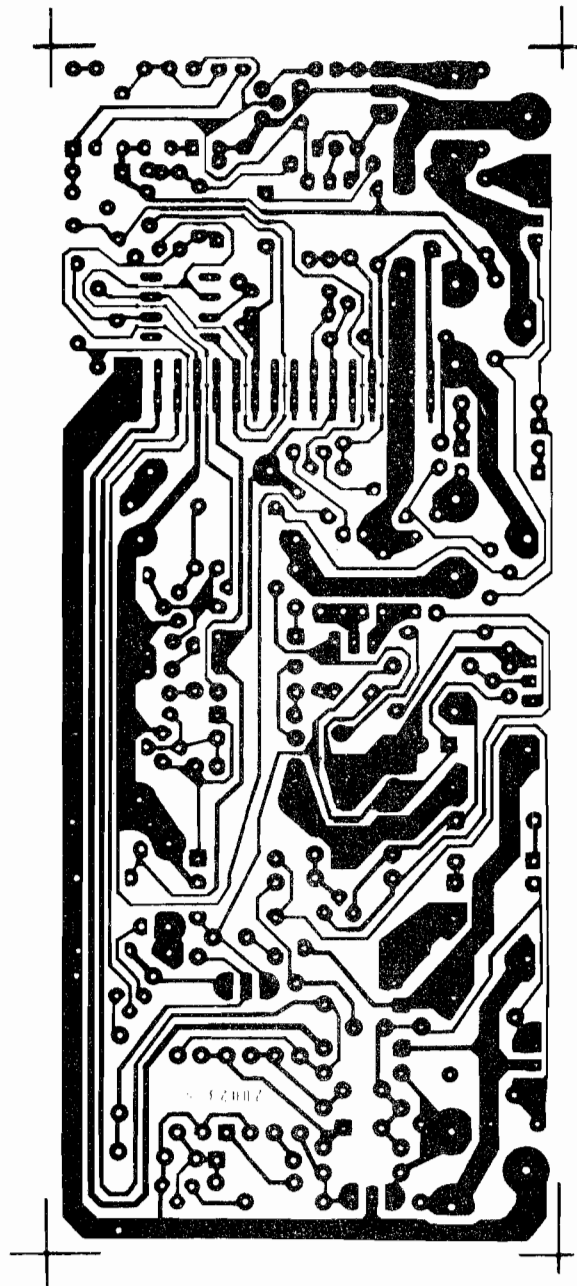

CARVER MODEL M-400 MAGNETIC FIELD POWER AMPLIFIER

LEFT CHANNEL AMPLIFIER

Foil Pattern Diagram

This is a BLANK page

or

a schematic Diagram that was attached after the last page

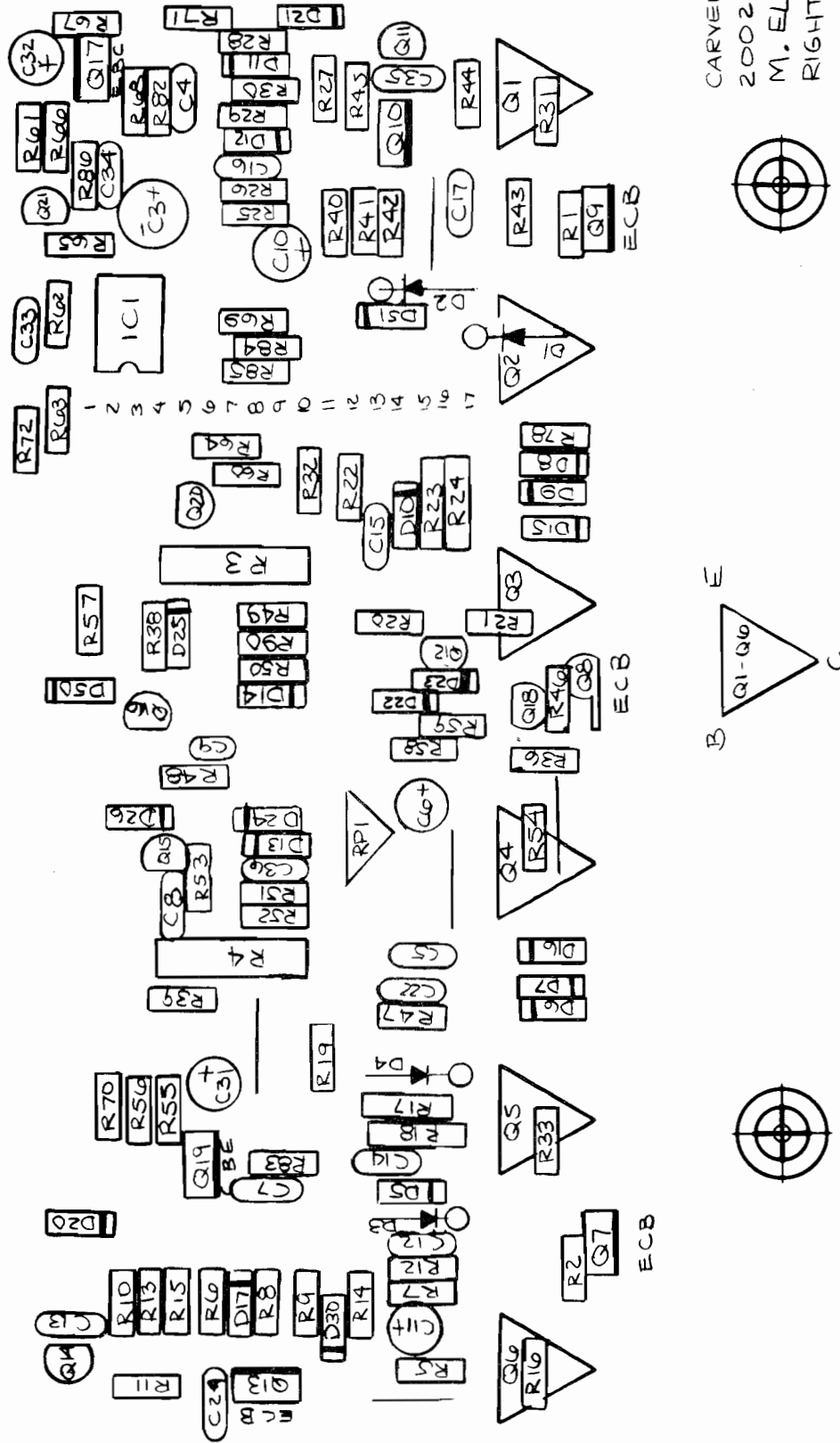

This is a BLANK page

or

a schematic Diagram that was attached after the last page

CARVER CORPORATION
 M4004-LEFT AMP
 20023-8 REV 0
 M.ÉLAINE LENO

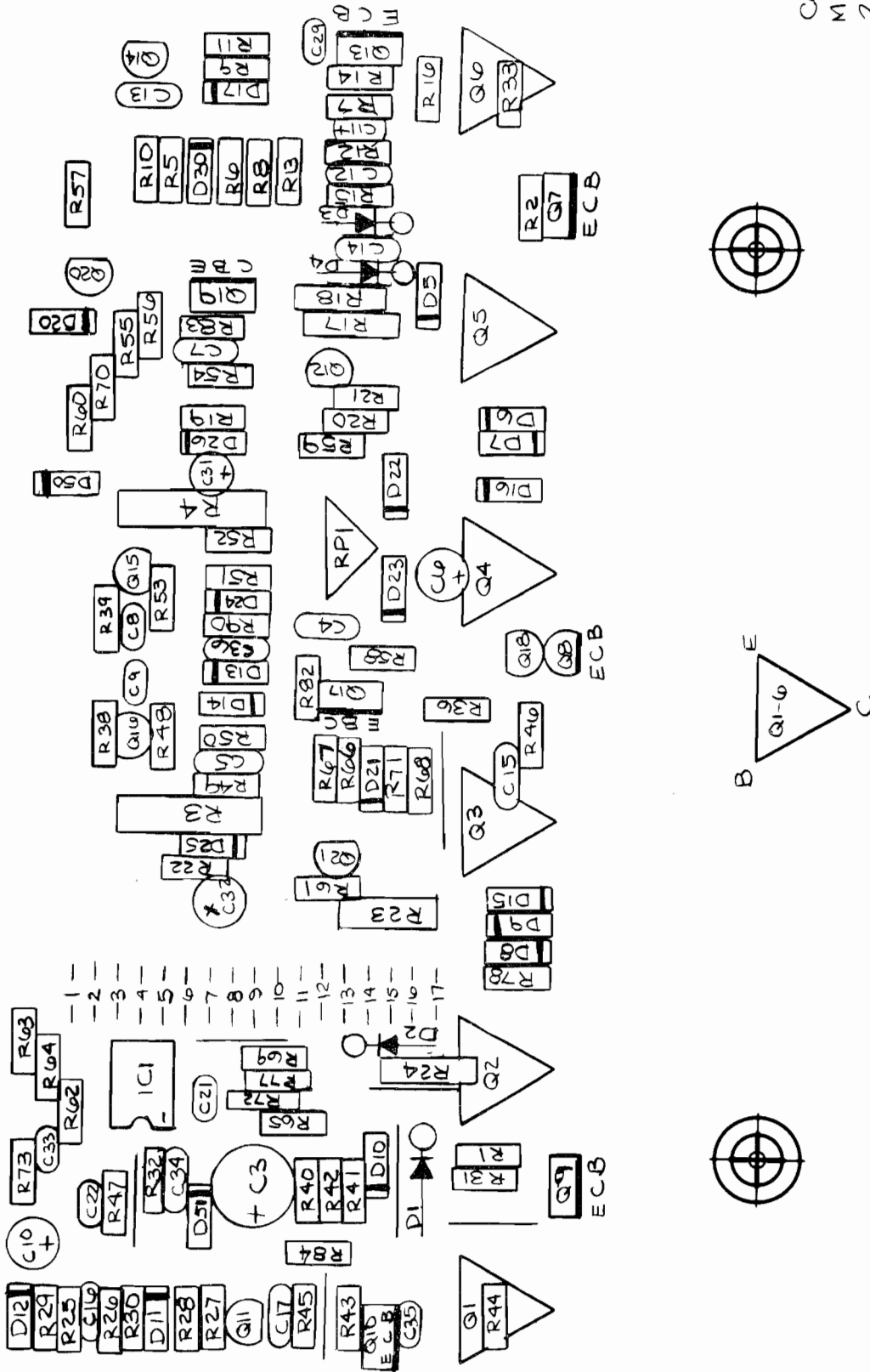

CARVER MODEL M-400 Magnetic Field Power Amplifier

DISPLAY

Schematic

NOTES-
 IC1 IC2 ARE 4136
 UNLESS OTHERWISE NOTED
 ALL DIODES ARE SRS05W

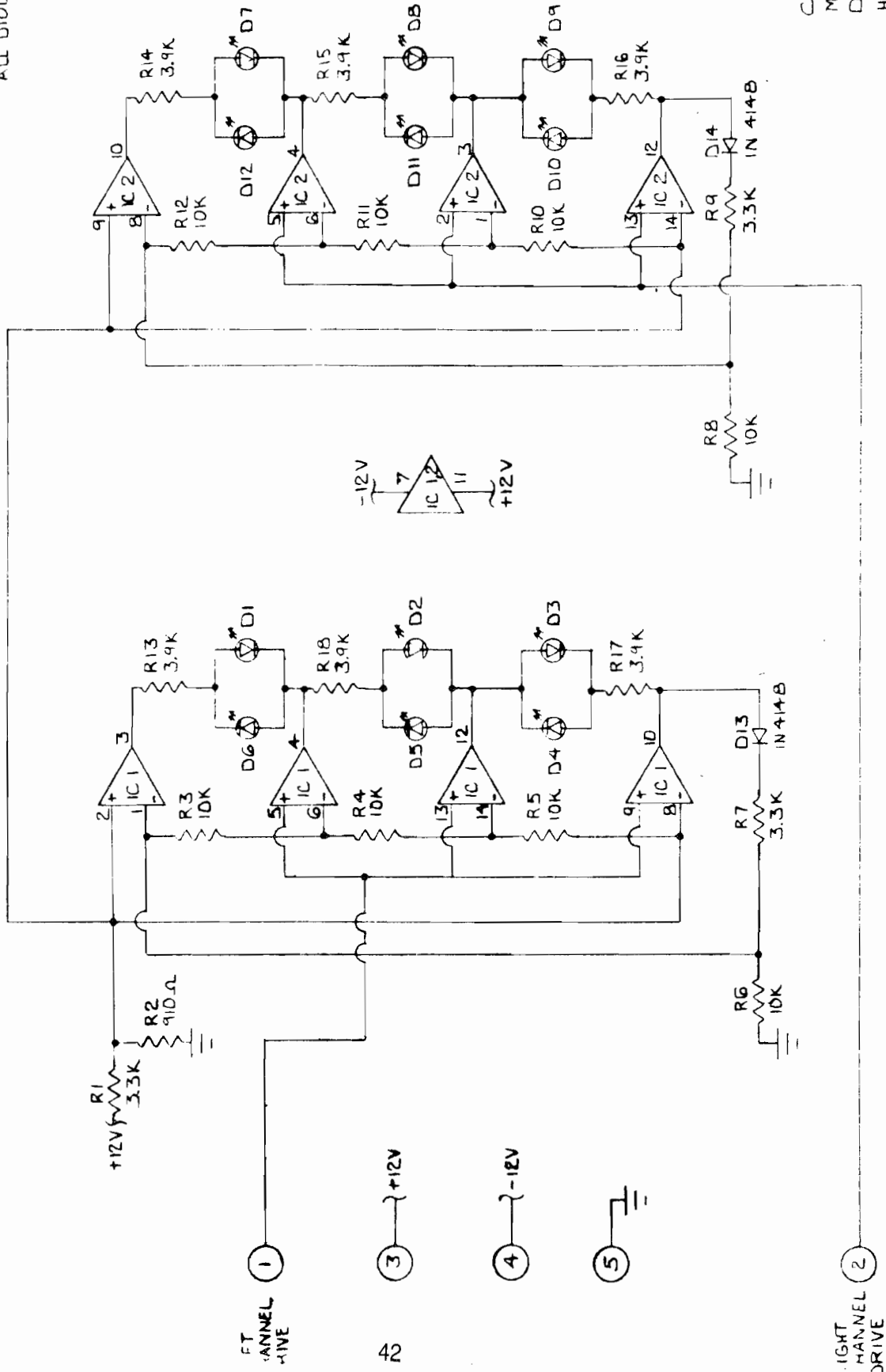

CARVER CORPORATION
 M-400 20020-3 RE
 DISPLAY BOARD
 HV 10-12-79
 Checked 3/4/81 KML

CARVER MODEL M-400
 MAGNETIC FIELD POWER AMPLIFIER
 DISPLAY
 Parts Locator

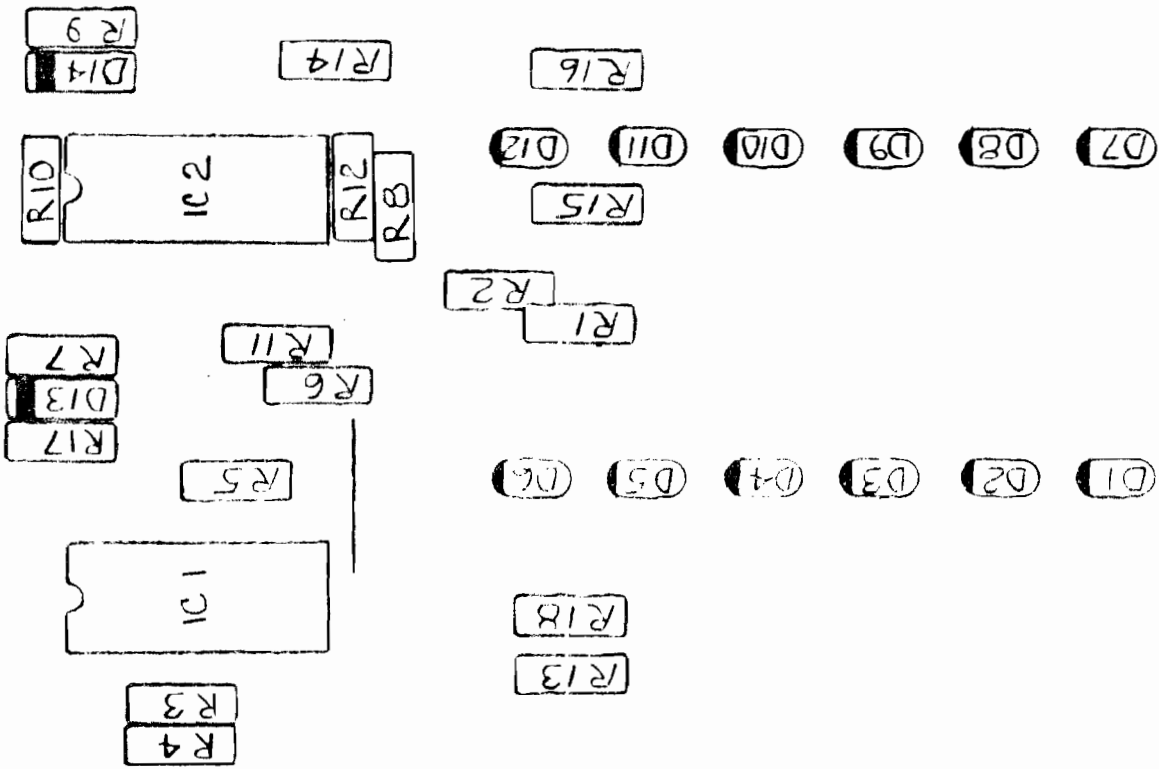

CARVER CORP.
 M-400 DISPLAY
 20020-3

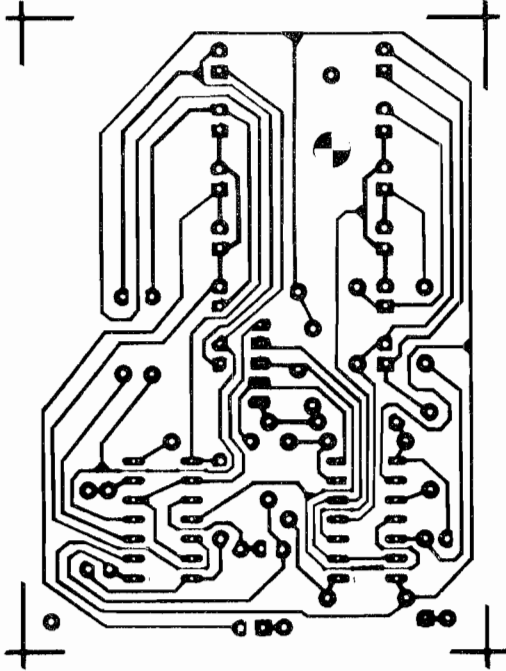

CARVER MODEL M-400
MAGNETIC FIELD POWER AMPLIFIER
DISPLAY
Foil Pattern Diagram

5. TEST TO SPECIFICATION

Preliminary Notes

This procedure is outlined with reference to Section 6, so that if a malfunction is indicated by a test, refer to the same-numbered part of Section 6 for troubleshooting.

It is recommended that the complete Test to Specification be repeated after repair and a minimum of 24 hours of idle burn-in.

Most transistors and diodes in the M-400 may be checked in-circuit.

Use an ohmmeter on the RX1, RX2 or 2K scale. With the M-400 power off and filter capacitors (75V) discharged, measure the forward-biased resistance of the diode or transistor junction and verify a reading of 400 to 700 ohms on a typical DVM for a good device. Actual readings on good devices will vary from meter to meter; some meters do not have sufficient test voltage to turn on a semiconductor. The shorted or open device is usually revealed quickly using this in-circuit method.

CAUTION: BEFORE MAKING ANY MEASUREMENTS INTERNAL TO THE M-400, UNLESS OTHERWISE SPECIFIED, MAKE CERTAIN THE LINE CORD IS UNPLUGGED AND THE 75V POWER SUPPLY CAPACITORS ARE DISCHARGED.

Wait at least 5 minutes after unplugging the amplifier to ensure that these capacitors are discharged. USE EXTREME CAUTION when taking any measurements with power on.

Necessary Equipment includes:

- (1) Audio Signal Generator,
(Distortion less than 0.02% THD)
- (2) DVM,
- (3) High Input Impedence, Dual-Trace Oscilloscope, (with Line-Freq. Trigger)

- (4) 2 x 250 Watt, 8 ohm load resistors,
- (5) Distortion Analyzer,
(Recommend: Sound-Tech 1700A.)
- (6) Variac fused at 15A.

5.1 Initial Power Up

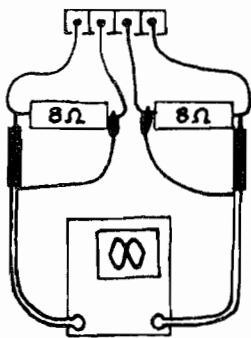

Connect Audio Generator signal output to both input channels in parallel, connect 8 ohm loads to speaker terminals. Connect dual-trace scope inputs across 8 ohm loads so that test equipment grounds connect to the two CENTER/INNER speaker terminals, while the hot leads connect to the OUTER terminals on the M-400. Leave load resistors connected throughout test.

Note that the two output displays on the scope will always appear 180 degrees out of phase.

Keeping signal generator output low, plug M-400 line cord into Variac output and SLOWLY turn voltage up to 100% of line. Verify that both channels pass a very low level signal (1 Vrms out).

5.2 Calibrate Supply Voltage At Idle

Place a DVM probe on the collector (outside case) of Q6 output transistor, either channel, with rear panel transistor cover removed. Adjust RP 1 of Original Power Supply, RP 2 of New Power Supply to +75.5 VDC.

Perform this calibration within 10 seconds of initial power-up, so as to avoid risk of venting 80V filter capacitors. Power M-400 down if unable to reduce voltage at Q6 below 76V.

Check pos. and neg. 12V supply at pins 7 and 4 of the Left channel amplifier op-amp (8-pin DIP, TL081).

5.3 Triac Firing

Set scope to trigger at line frequency. Place scope probe on the anode of the Triac TR1 (middle lead). Verify smooth and symmetrical firing at and below 130V of line (rotate Variac to check).

"Smooth" firing is indicated by a firing rate of 120 Hz or twice the line frequency. "Rough" firing, once every two or three cycles, will produce a jittery scope waveform and a slight "ticking" noise from the chassis of the M-400.

"Symmetrical" firing means that both pos. and neg. sides of the line are chopped equally by the triac. See illustration:

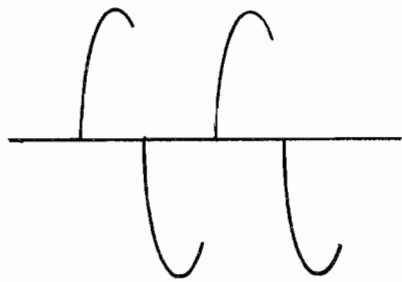

GOOD - Smooth, Symmetrical

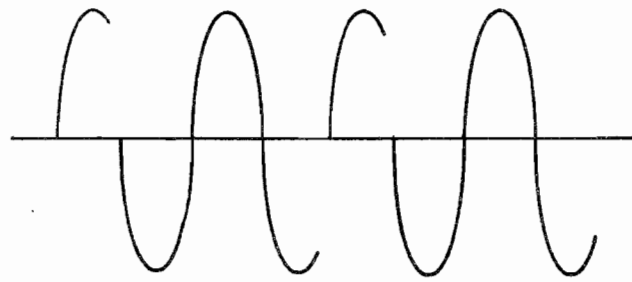

BAD - Rough

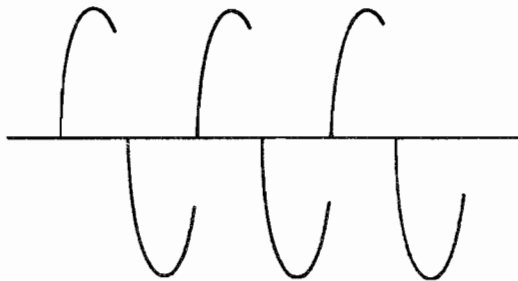

BAD - Asymmetrical

NOTE: Back-panel switch may need to be DOWN in the "STEREO" position for smooth firing. This is normal for the Original Supply.

AC line plug polarity may need to be reversed to obtain these displays.

5.4 Bias Adjustment

Step 1 - Left Channel - Place DVM probes across emitter-base of output transistor Q3, Left amp:

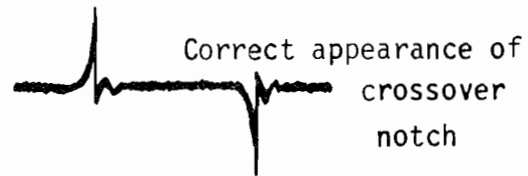
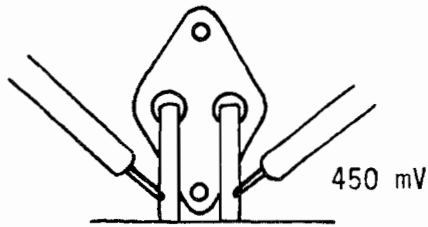

Adjust RP1 (Left amp) for a DVM reading of 450 mV at idle (no signal).

Step 2 - Right Channel - Operate the M-400 at 2K Hz, 1V output. Using the Distortion Analyzer, observe (and measure in cm on the scope) the Left amp crossover notch. Connect the D.A. to the Right amp output and adjust RP1 (Right amp) for the same size notch as measured for the Left amp.

It is important that the bias be set by this method before driving the M-400 at full power, or when the chassis is at room temperature.

5.5 Commutator Test

Drive the M-400 with a 2K Hz signal to obtain 32V at the outputs. Clip a lead from the + lead of

C-14 - Original Supply

C-3 - New Supply

to ground to prevent Integrator Shutdown. Use one channel of the scope to monitor one channel output at a time, using the other channel for a scope probe.

Place probe on each of the following test points. Collector (outer case) of:

Q5 for +75V
Q4 for +50V
Q3 for -50V
Q2 for -75V

each channel. Verify correct switching per illustration below.

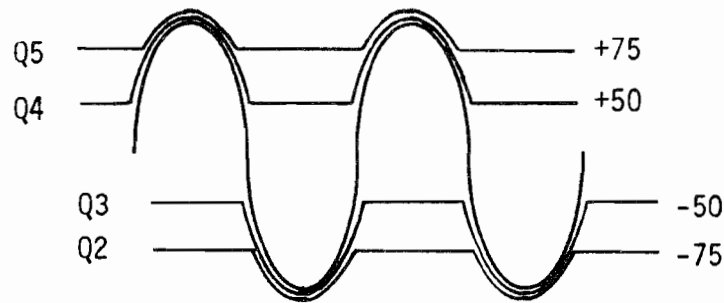

5.6 Distortion

Drive both channels at 2K Hz to rated power, 40V RMS output into 8 ohms. Verify THD less than 0.09%, 0.05% with IHF "A" filter at D.A. input.

5.7 Integrator Shutdown

Remove ground-lead from Integrator cap. Drive both channels at 2K Hz just at clipping. Shutdown should occur no less than 15 seconds (20 sec. typical). To reset shutdown, briefly touch the ground test-lead to the + lead of the Integrator cap. Reduce signal generator output to less than 10V at M-400 outputs.

5.8 Over-Current/Short Circuit Shutdown

Reconnect ground lead to Integrator cap. Drive both channels 10V out at 2K Hz. Place a direct short across one of the speaker outputs. Shutdown should occur. Hold short in place until unshorted channel comes on and cycles off and on several times.

5.9 Low Frequency/DC Shutdown

Drive both channels to 40V at 5 Hz. Pull one channel input cable, verify shutdown at this time. Repeat by pulling other input.

Reduce input level to 10 volts out. Remove ground lead from the Integrator cap.

5.10 Recheck Commutators (Section 1.3) and Bias (Section 1.4).

5.11 Display

Drive both channels briefly to 40V output at 200 Hz. Verify top LED's ("0 dB") lit within 5V of clipping. Reduce input level gradually while observing display to verify display tracks within one LED.

6A. TROUBLESHOOTING TO SPECIFICATION

Refer to key number in Section 5 for reference to test procedure.

6.1 Unable to properly energize unit:

Draws current, no output signal, etc. Refer to Troubleshooting, Major Failures Section 6B.

6.2 Unable to Calibrate 76.5 VDC supply:

Replace OC1, reset voltage.

6.3 Triac Misfiring

(Rough or Asymmetrical Firing): On original supply board, replace Triac (TR1), Diac (BD1), LDR (OC1). If this is not effective, modify the primary as follows:

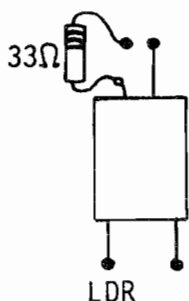

Install 33 ohm $\frac{1}{4}$ watt resistor in series with the cathode of OC1 as shown, and change C11 to 0.015 uF mylar capacitor.

On new supply board, adjust RP1 for smooth firing. If not effective, replace Triac, Diac, Optocoupler.

Always recheck +75.5V supply per Section 5.2.

6.4 Unable to Adjust Bias:

Check/replace Q18, Q8, Q12. If this is not effective, check + and - 12V supply. Replace appropriate zener regulator.

If notch is excessive in both channels, suspect $\pm 12V$.

If one channel bias problem, suspect amp bias network problem.

6.5 Commutator Switches Improperly:

Commutator failure is usually limited to a "lock-up" or "lock-down" of the 75V commutator, as shown:

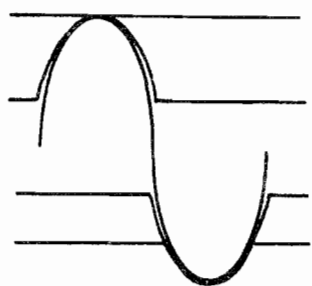

+75 Locked Up

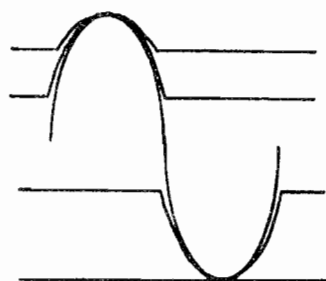

-75 Locked Up

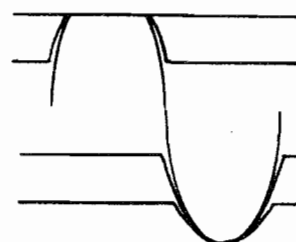

+75 Locked Down

Problems with the +75 commutator are usually related to failure of D3 and Q6, -75: D1 and Q1, for both amplifiers. Check all semiconductors within the commutator areas shown in the amplifier schematic block-diagram overlays.

6.6 Does Not Make Full Power:

First verify commutators are functioning correctly, then check to see that the +75V and -75V supply voltages do not drop below 69V at full output. Supply below this level indicates a defective optocoupler (OC1).

6.7 Integrator Shutdown Early or Inoperative:

For the original supply, use a DVM probe to verify that C14 charges to a minimum of 15V, when the M-400 is driven at full power. Replace C14, check/replace Q2, Q3.

For the new supply, verify C3 charges to no less than 15V. Replace as necessary. Check/replace Q2, Q3, Q4.

6.8 Over-Current Protection Faulty:

Verify 12V supply OK, check/replace Q1 (supply), Q15, D24, or D26 (amplifiers).

6.9 Display Malfunction:

Verify 12V supply OK at pins 7 and 11 of 4136 ICs on display board. Verify 5-pin connector socket is intact. If mistracking exists on original supply, replace Q4, Q5, C6, C8 as necessary.

6B. TROUBLESHOOTING MAJOR FAILURES

6B.1 Unit Blows Fuse

This failure must be checked on the Variac with all test connections made. Bring Variac up gradually. A properly functional unit will not pass signal or "turn on" below about 50% of line voltage.

If unit passes signal at a low line voltage (30 - 40%), and draws current above 60%, replace Triac, Diac, Optocoupler.

6B.2

If current is drawn only above 50% line, with or without a signal at either output channel, suspect a bridge rectifier in the supply secondary. Failures are most common at the 25V level, so remove the two red wires from the Mag Coil secondary, and check for current draw. Replace 25V rectifier (installing new part of foil side of the original supply board). Also check all four junctions of all bridge rectifiers.

6B.3

Blew fuse and smoked, or blows fuses randomly (every hour or so). Begin by usually inspecting the area near the mountings of the 80V/4000 uF filter capacitors for electrolyte released by venting as a result of overvoltage. Overvoltage is usually a result of optocoupler drift, so replace OC1 and 80V filters if venting occurred. Reset supply voltage.

If smoke was a result of burned parts on the amp board(s), and the filters look OK, troubleshoot for shorted semiconductors in the appropriate (smoked) amplifier card. See 6B.4.

6B.4

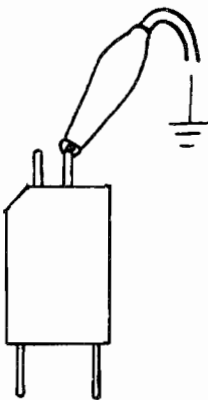

Will Not Come Out of Protection. To bypass protection and regulator, and force the M-400 to turn on, attach a grounded clip-lead to the anode side of the optocoupler. With no regulation, the supply will draw current, so do not advance Variac beyond 70% line. Drive both channels at a low level, monitor outputs on scope, bring Variac up slowly. The channel which has offset and supply ripple is the defective channel.

Check:

Outputs Q3, Q4

Commutators Q1, Q2, Q5, Q6

Drivers Q7, Q9

Bias Transistors Q12, Q18, Q8

Limiter Transistors Q15, Q16

Limiter Diodes D26, D25

Troubleshooting an amp board is facilitated by replacing all suspect parts, then installing the board and only the output transistors Q3 and Q4. If the amp is OK it will pass signal (15V output or less).

6B.5

One channel does not pass signal, but no current is drawn, and other channel meets spec. This can be caused by:

(1) Defective input jack, which prevents signal from reaching amp. Insert and remove input plugs. You should feel the jack grip the tongue of the plug before the sleeve part mates. If the tongue does not tightly clip in, observe back side of jack through vents in bottom cover. If metal bracket part of jack assembly appears pushed back or sitting at an angle, replace input jack.

(2) An open predriver transistor will cause a channel to behave as shown below on scope. Replace as necessary.

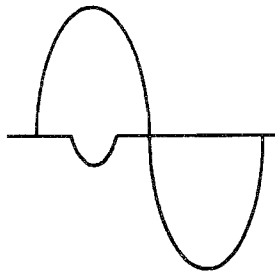

POSITIVE Predriver bad

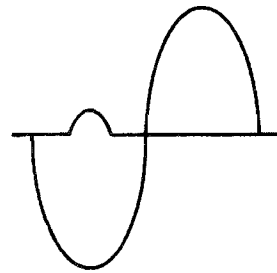

NEGATIVE Predriver bad

Drive to full power for this display.

7. DISASSEMBLY

This section will outline how to accomplish disassembly for minor repairs and for major failures.

7.1 Normal specification test must be performed with front-panel and transistor covers removed. The front panel comes off when four phillips screws on the front edge of the case sides are removed. Rear cover mounts by four phillips screws.

Some minor repair operations may also be performed without further disassembly. These include:

Display

Triac, Diac, Optocoupler

7.2 The foil side of the power-supply board may be exposed by removing the Mag Coil from its four mounts (screws through Well-Nuts), and rotating the mag coil out of the case on its wiring harness. Remove any high-voltage insulation paper under the angle bracket which may mount the lower-front corner of the power supply board to the chassis.

7.3 Remove the three-sided case by removing 13 phillips screws from top, sides and bottom. Place unit on its rear and spread case to slide it off the chassis. Case must be spread enough to clear Mag Coil well-nut mounts.

7.4 Remove the 80V supply filters to gain access to the foil side of the supply board behind the Mag Coil. Installation of 80V filters REQUIRES that star-washers be in place and mounting screws be fully tightened.

7.5 To remove Left channel amp, remove all six T0-3 transistors, and remove mounting screws and nuts for both drivers and the bias transistor. Grasp each output transistor socket by its base/emitter brackets and pop the sockets out of their fitted wells in the inside rear chassis walls. Each socket will fit into a hole in the upper rim of the chassis. Pull the board up, off of its connector. Rotate it forward out of the chassis, unsolder the output wire.

- 7.6 The Right amp board may be removed by pulling all T0-3 transistors, drivers and bias, and pulling board out and up off the supply connector socket.
- 7.7 When reinstalling amp boards verify adequate thermal compound on T0-3s, drivers.

NOTE: For removal of the amp cards, a 3/16 in. nut-driver is an especially useful tool to remove the nuts which hold the Driver and Bias transistors to the chassis.

8. APPENDICES

Appendix A: Design History

A.1 A brief outline of the changes made in the electronics and mechanical design of the M-400 is offered here, keyed-in to the serial numbers at which the changes were made. The most significant change was the introduction of the New Supply circuit board. A separate outline of the major differences between the Original and New Supply circuits will be found in Appendix A.2.

DESIGN HISTORY OUTLINE

<u>Design Aspect</u>	<u>Series</u>
Hard-wired amp connectors. Rt. Ch. bias pot facing side.	1 - 300
Hex-screws through front panel	1 - 450
Small (T0-5) Triacs.	0 - 1750
Amp-card removal holes in top rim of chassis.	600 - present
Dual, paralleled Triacs.	1750 - 2000
Present (T0-3) Triacs.	2000 - present
NEC 25B600 Output Transistor, sub for C-3000 output.	1800 - 2000
Transit-washer added to bottom to prevent display failure.	2500 - present
Charcoal finish option offered.	5000 - present
Cutouts added to chassis between rows of output transistors, improving access to drivers and bias.	5000 - present
Original Power Supply w/rear-panel switch.	0 - 7500
New Power Supply w/o rear-panel switch.	7500 - present

A.2 The New Power Supply

The revised Power Supply circuit incorporates the following significant differences from the Original. Refer to schematic diagram.

- 1) No external supply-regulator reference switch (Stereo/Mono switch).
- 2) Two regulator transistors which allow the regulator to track both positive and negative sides of the supply secondary symmetrically.
- 3) A true opto-transistor replaces the LDR. Far less susceptible to heat-induced drift, the opto-transistor is placed in a diode bridge, and a separate trim control is provided (RP1) to adjust for "rough" triac firing at idle.
- 4) The shutdown comparator is now a differential pair rather than an op-amp. The shutdown triplines are unchanged.
- 5) To eliminate channel mistracking and low-frequency weighting from the display, the voltage scaling log amps were omitted. This means that a higher output level is required for the display to respond, on the New Supply.

In troubleshooting the New Supply, refer to the section of Major Failures, Section 6B.4. To force the New Supply to turn on, if an amplifier has failed, use a well-insulated metallic tool to short the anode and cathode of the Triac (middle and rear pins). Hold this short in place while turning up the variac slowly. The channel with offset and ripple is defective.

Appendix B: References

For standard test conditions, refer to IHF-A-202 (1978) published by the Institute of High Fidelity, Inc., 489 5th Ave., New York, NY 10017.

Appendix C: Parts

The model-stock parts kit list which follows is offered by Carver Technical Services. A separate price sheet is also available. All parts orders are to be referenced to the Generic Part No., which is usually printed on the part itself, until further notice. Phone-in parts orders for parts in the model-stock will be turned around within five days. Orders for other parts or for tested subassemblies may take longer.

M-400 REPAIR PARTS KIT

This is a basic repair parts kit list, it is by no means inclusive. Most speciality parts are included, except for large metalwork pieces, which can be special-ordered. Please inquire to the factory regarding prices of parts not listed.

<u>Part Description</u>	<u>Kit Qty</u>	<u>Part Description</u>	<u>Kit Qty</u>
<u>TRANSISTORS</u>		<u>DIAC</u>	
MPS-A93	4	GT-40	4
MPS-8097	8	<u>LDR</u>	
MPS-8093	8	VTL-5C3	8
2N 3403	4	<u>BRIDGE RECTIFIER</u>	
TIS 98	4	25V, 50V: KBP02	6
2955	4	80V: BR-122	4
3055	4	<u>DIODES</u>	
V04	4	IN4742	4
V60	4	IN4148	8
C 2000	6	LED:SR505W	6
C 3000	6	IN 4004	4
C 4000	4	<u>CONNECTORS: PINS</u>	
C 5000	4	24K Gold 5-Pin	10
FT 417B	6	24K Gold 7-Pin	2
FT 317B	6	24K Gold 10-Pin	2
<u>ICs</u>		<u>MISC.</u>	
4136	4	Spkr Terminal Strip	4
TL081	4	T0-3 Transistor Socket PCB-Mount Blk Plastic	4
<u>TRIAC</u>			
Q2025	6		

M-400 REPAIR PARTS KIT (Continued)

<u>Part Description</u>	<u>Kit Qty</u>	<u>Part Description</u>	<u>Kit Qty</u>
Input Jack Dual PCB-Mount Blk Plastic	4	<u>FUSE</u>	
		AGC-15	10
<u>TRIMPOTS</u>			
1K Ohm	4		
5K Ohm	4		
<u>FILTER CAPACITOR</u>			
4000 uF 80V	2		
<u>HARDWARE</u>			
Fuse Holder AGC (HKP)	4		
Feet	10		
#6-3/8 Blk Sht-Metal Screw	30		
#4-3/8 Blk Sht-Metal Screw	20		
#4-3/8 Blk Machine Screw	10		
#4-5/8 Blk Machine Screw	10		
#10-3/8 Blk Machine Screw	10		
M3-16 mm Blk Machine Screw	10		
#6-5/8 TCS Phillips "F"	10		
Well-Nut B8-32	10		

Appendix D: Service Bulletins

This section is reserved for Update or Specific Malfunction bulletins.

OVER CURRENT TRIP

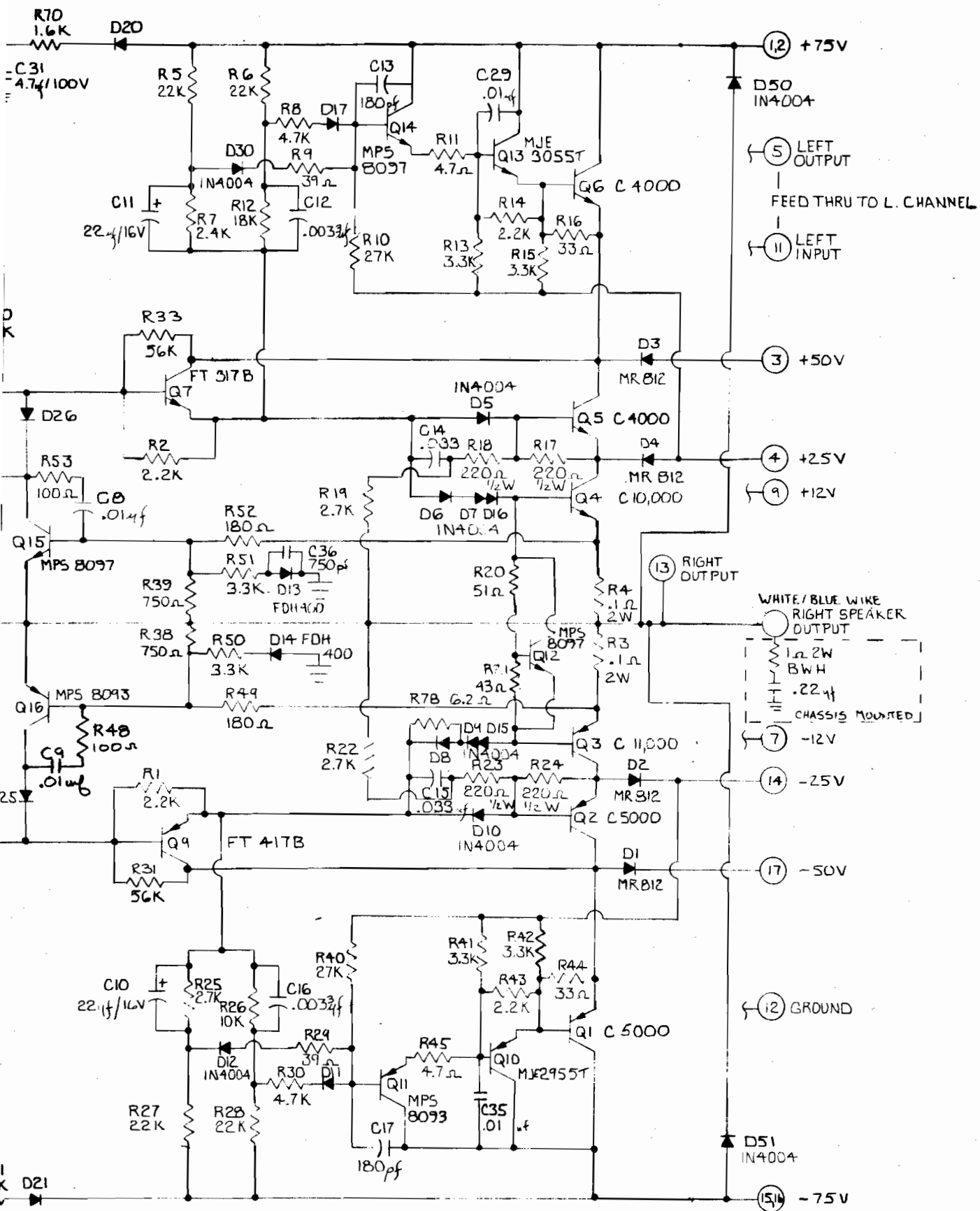

NOTES:
 ALL DIODES ARE 1N4148 UNLESS
 OTHERWISE MARKED.
 IC 1- TLO 81

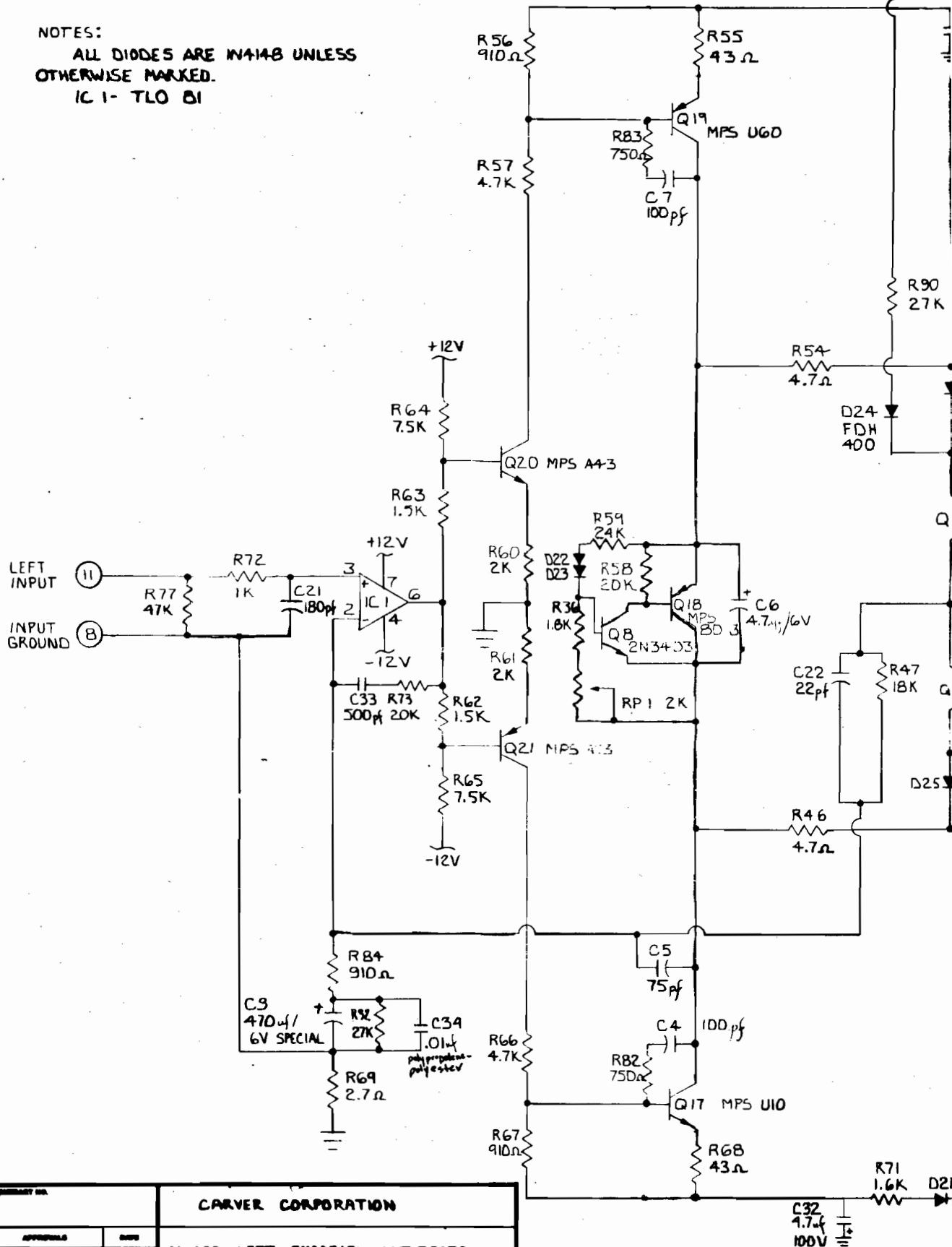

DESIGNER'S NO.		CARVER CORPORATION			
APPROVED	DATE	M-420 LEFT CHANNEL AMP BOARD			
<i>[Signature]</i>	<i>[Date]</i>	SIZE	FORM NO.	REV. NO.	REV.
				20023-B	0
SCALE		DRAWN <i>[Signature]</i>			

CURRENT TRIP

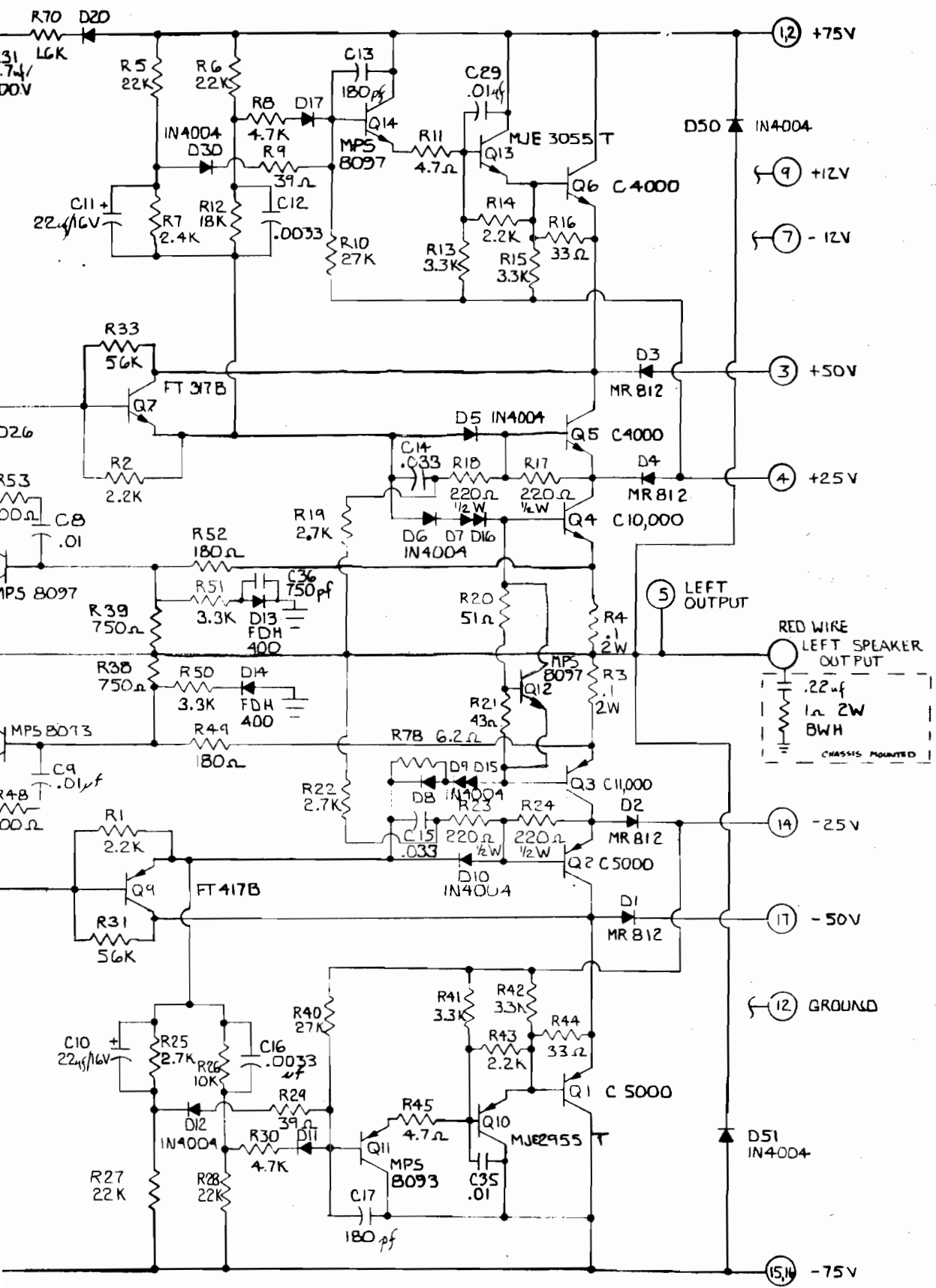

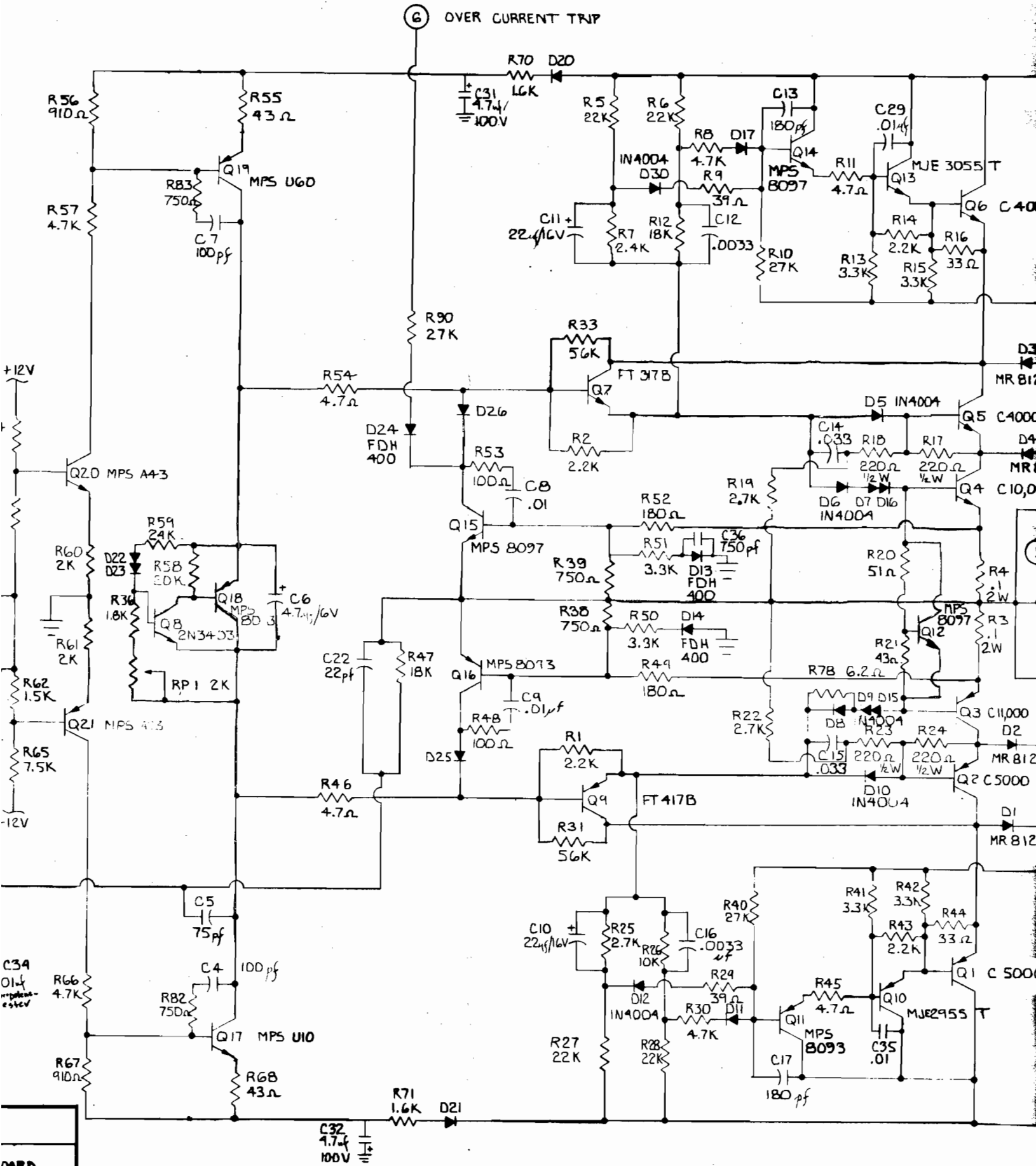

DARD	
MAX	O

DATE 12-1-80	PRODUCT M-400	PCB PWR SUPPLY
--------------	---------------	----------------

SERVICE PRIORITY	All Units
	Serial Nos. (specify)
	RTS / Dealer Stock
	✓ Specific Complaint "TICKING" IN SPEAKERS

PROCEDURE

COMPLAINTS OF TICKING, PUTTING OR MOTORBOATING IN LOUDSPEAKERS CONNECTED TO M-400 SHOULD BE DEALT WITH AS FOLLOWS:

1. MAKE CERTAIN NOISE DOES NOT GO AWAY WHEN THE PREAMP IS DISCONNECTED FROM THE POWER AMP. IF THE M-400 IS QUIET WITH NO INPUT:
 - A. PLUG M-400 POWER CORD INTO THE WALL INSTEAD OF INTO PREAMP OUTLET.
 - B. MOVE M-400 AWAY FROM OTHER COMPONENTS.
 - C. REROUTE PATCHCORDS AND AC LINES.
2. TRY BOTH POSITIONS OF THE BACK-PANEL SWITCH ON THE M-400. IF NOISE GOES AWAY IN EITHER POSITION IT IS OK TO LEAVE IT IN THAT POSITION REGARDLESS OF LOAD IMPEDENCE OR STEREO / MONO USE.
3. IF TICKING NOISE PERSISTS, PERFORM THE FOLLOWING MODIFICATION AND ADJUSTMENT:
 - A. REMOVE FRONT-PANEL.
 - B. ADD ONE 56Ω 1/4 W RESISTOR IN SERIES WITH ONE LEG OF THE LED HALF OF THE OPTOCOUPLER ON THE POWER SUPPLY PCB:

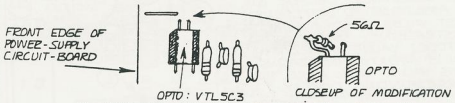

- C. MONITOR DC VOLTAGE FROM CASE OF EITHER "C-3000" OUTPUT TRANSISTOR TO CHASSIS GROUND. POWER-UP M-400 WITH 120V LINE, NO SIGNAL. SET TRIMPOT ON SUPPLY BOARD FOR 75V. REPLACE BACK COVER.
- D. REPLACE FRONT PANEL.